

DATA SHEET

vibro-meter®

VM600^{Mk2} / VM600

RPS6U

rack power supplies

KEY FEATURES AND BENEFITS

- From the vibro-meter® product line
- Power supply for VM600^{Mk2}/VM600 ABE04x 19" system racks with a height of 6U
- Input: AC-input and DC-input versions
- Outputs: +5 V_{DC} and ±12 V_{DC}
- Output over-voltage, short-circuit and overload protection
- Status indicators
- High-power, high-performance, high-efficiency
- Minimal derating within the operating temperature range

APPLICATIONS

- VM600^{Mk2}/VM600 machinery protection and/or condition monitoring systems
- One RPS6U rack power supply powers a full rack of modules (cards)
- Two RPS6U rack power supplies enable rack power supply redundancy



VM600^{Mk2} RPS6U

VM600 RPS6U



DESCRIPTION

The VM600^{Mk2}/VM600 RPS6U rack power supplies are designed for use in the VM600^{Mk2}/VM600 series of machinery protection systems and condition and performance monitoring systems, from Meggitt's vibro-meter® product line.

A VM600^{Mk2}/VM600 RPS6U rack power supply is installed in the front of a VM600^{Mk2}/VM600 ABE04x system rack (19" system racks with a standard height of 6U) and connects via two high-current connectors to the VME bus of the rack's backplane. The RPS6U power supply provides +5 V_{DC} and ±12 V_{DC} to the rack itself and all installed modules (cards) in the rack via the rack's backplane.



Information contained in this document may be subject to export control regulations of the European Union, USA or other countries. Each recipient of this document is responsible for ensuring that transfer or use of any information contained in this document complies with all relevant export control regulations. ECN N/A.

DESCRIPTION *(continued)*

Either one or two VM600^{Mk2}/VM600 RPS6U rack power supplies can be installed in a VM600^{Mk2}/VM600 ABE04x system rack. A rack with one RPS6U power supply (330 W version) supports the power requirements for a full rack of modules (cards) in applications with operating temperatures up to 50°C (122°F).

Alternatively, a rack can have two RPS6U power supplies installed in order to either support rack power supply redundancy or in order to supply power to the modules (cards) non-redundantly over a wider range of environmental conditions.

A VM600^{Mk2}/VM600 ABE04x system rack with two RPS6U power supplies installed can operate redundantly (that is, with rack power supply redundancy) for a full rack of modules (cards). This means that if one RPS6U fails, the other will provide 100% of the rack's power requirement so that the rack will continue to operate, thereby increasing the availability of the machinery monitoring system.

Note: This is known as a redundant RPS6U rack power supply configuration.

A VM600^{Mk2}/VM600 ABE04x system rack with two RPS6U power supplies installed can also operate non-redundantly (that is, without rack power supply redundancy). Typically, this is only necessary for a full rack of modules (cards) in applications with operating temperatures above 50°C (122°F), where RPS6U output power derating is required.

Note: Even though two RPS6U rack power supplies are installed in the rack, this is not a redundant RPS6U rack power supply configuration.

The number and type of RPS6U power supplies installed in a VM600^{Mk2}/VM600 ABE04x system rack, together with the number of modules (cards) installed and the environmental conditions, helps determine the mode of operation of the RPS6U power supplies as either redundant or non-redundant. See also **Ordering information on page 16**.

Different versions of the RPS6U rack power supply enable a VM600^{Mk2}/VM600 ABE04x system rack to be powered using external AC and/or DC mains supplies. All RPS6U power supplies support a wide input voltage range.

A power supply check relay, available on the associated rear panel at the rear of a VM600^{Mk2}/VM600 ABE04x system rack, is used to indicate that the RPS6U power supplies are operating normally. Refer to the *VM600^{Mk2}/VM600 ABE04x system rack data sheet* for further information.

In applications where the VM600^{Mk2}/VM600 ABE04x system rack is powered by an AC mains supply, a VM600^{Mk2}/VM600 ASPS auxiliary sensor power supply can also be included in the rack. The ASPS provides +24 V_{DC} outputs which can be used by external sensor/measurement chain hardware such as front-end sensors, signal conditioners and galvanic separation units.

For further information, contact your local Meggitt representative.

SPECIFICATIONS

Electrical

(At 25°C (77°F) with nominal line input voltage and maximum combination power load, unless otherwise stated.)

Parameter	AC-input version	DC-input versions	
	RPS6U AC	RPS6U 24 DC	RPS6U 110 DC
Nominal input (line) voltage	115/230 V _{AC} or 220 V _{DC}	24 V _{DC}	110 V _{DC}
Input voltage range	90 to 132 V _{AC} and 180 to 264 V _{AC} (autoranging) or 178 to 264 V _{DC}	18 to 32 V _{DC}	80 to 145 V _{DC}
Input frequency	47 to 63 Hz	Not applicable	
Input current	6.4 A _{RMS} max. at 115 V _{AC} . 4 A _{RMS} max. at 230 V _{AC} .	30 A max.	6 A max.
Efficiency	84% typ.	83% typ.	85% typ.
Inrush current	< 10 times the nominal input current	< 10 times the nominal input current	< 10 times the nominal input current
Nominal output (supply) voltages	+5 V _{DC} up to 50 A, +12 V _{DC} up to 8 A, -12 V _{DC} up to -4 A	+5 V _{DC} up to 50 A, +12 V _{DC} up to 8 A, -12 V _{DC} up to -4 A	+5 V _{DC} up to 50 A, +12 V _{DC} up to 8 A, -12 V _{DC} up to -4 A
Output power <small>See note 1 below</small>	330 W max.	330 W max.	330 W max.
Factory adjustment	+5.41 V _{DC} ±0.02 V, ±12.5 V _{DC} ±0.05 V (at 60% max. output power)	+5.41 V _{DC} ±0.02 V, ±12.5 V _{DC} ±0.05 V (at 60% max. output power)	+5.41 V _{DC} ±0.02 V, ±12.5 V _{DC} ±0.05 V (at 60% max. output power)
Load range	+5.35 V _{DC} nom. (5.35 to 5.45 V accuracy with a load of 3 to 50 A). +12.5 V _{DC} nom. (12.2 to 12.8 V accuracy with a load of 0 to 8 A). -12.5 V _{DC} nom. (-12.2 to -12.8 V accuracy with a load of 0 to 4 A).	+5.35 V _{DC} nom. (5.35 to 5.45 V accuracy with a load of 3 to 50 A). +12.5 V _{DC} nom. (12.2 to 12.8 V accuracy with a load of 0 to 8 A). -12.5 V _{DC} nom. (-12.2 to -12.8 V accuracy with a load of 0 to 4 A).	+5.35 V _{DC} nom. (5.35 to 5.45 V accuracy with a load of 3 to 50 A). +12.5 V _{DC} nom. (12.2 to 12.8 V accuracy with a load of 0 to 8 A). -12.5 V _{DC} nom. (-12.2 to -12.8 V accuracy with a load of 0 to 4 A).
Ripple and noise (20 MHz bandwidth)	< 50 mV _{PEAK-TO-PEAK} for all outputs	< 50 mV _{PEAK-TO-PEAK} for all outputs	< 50 mV _{PEAK-TO-PEAK} for all outputs
Line regulation (±10% change in nominal input)	< ±1% for all outputs	< ±1% for all outputs	< ±1% for all outputs
Load regulation (±40% change from 60% max. output power)	< ±1% for +5 V _{DC} output. < ±2% for ±12 V _{DC} outputs.	< ±1% for +5 V _{DC} output. < ±2% for ±12 V _{DC} outputs.	< ±1% for +5 V _{DC} output. < ±2% for ±12 V _{DC} outputs.

(Continued on the next page ...)

SPECIFICATIONS *(continued)*

Parameter	AC-input version	DC-input versions	
	RPS6U AC	RPS6U 24 DC	RPS6U 110 DC
Output overvoltage protection	Yes, with automatic latch off	Yes, with automatic latch off	Yes, with automatic latch off
Output short-circuit and overload protection	Yes, with automatic recovery	Yes, with automatic recovery	Yes, with automatic recovery
Output power derating with convection cooling (natural ventilation)	2.5%/°C from 50 to 70°C for +5 V _{DC} output. 4%/°C from 55 to 70°C for ±12 V _{DC} outputs.	2%/°C from 50 to 70°C for +5 V _{DC} output. 3%/°C from 60 to 70°C for ±12 V _{DC} outputs.	2%/°C from 50 to 70°C for +5 V _{DC} output. 3%/°C from 60 to 70°C for ±12 V _{DC} outputs.
Output power derating with forced-air cooling	No derating required	2.5%/°C from 60 to 70°C for +5 V _{DC} output. No derating required for ±12 V _{DC} outputs.	2.5%/°C from 60 to 70°C for +5 V _{DC} output. No derating required for ±12 V _{DC} outputs.
Ordering number (PNR) <small>See note 2 below</small>	200-582-500-12h (VM600 ^{Mk2}) or 200-582-500-02h (VM600)	200-582-200-12h (VM600 ^{Mk2}) or 200-582-200-02h (VM600)	200-582-600-12h (VM600 ^{Mk2}) or 200-582-600-02h (VM600)

Notes

1. In 2016, the RPS6U rack power supply was improved to provide a higher output power of 330 W with higher-performance and higher-efficiency, which required a redesign of the underlying power supply circuitry.

Accordingly, the different versions of the RPS6U rack power supply in use are:

- Later versions of the RPS6U (PNR 200-582-x00-02h or later) that define the power as a total maximum output power of 330 W, with nominal output (supply) voltages of +5 V_{DC} up to 50 A, +12 V_{DC} up to 8 A and -12 V_{DC} up to 4 A.
Note: The total maximum output power of 330 W is a combination load for all outputs as the +5 V_{DC} and ±12 V_{DC} outputs are usually not simultaneously loaded to the maximum in practice. For example, if the +5 V_{DC} output is at its maximum rated load (5.35 V × 50 A = 267.5 W), then the combined loads on the +12 V_{DC} and -12 V_{DC} outputs must not exceed 62.5 W.
- Earlier versions of the RPS6U (PNR 200-582-x00-01h or earlier) that define the power as a rated power of 300 W, with nominal output (supply) voltages of +5 V_{DC} up to 35 A, +12 V_{DC} up to 6 A and -12 V_{DC} up to 2 A.

2. In 2021, VM600^{Mk2} (second-generation) machinery monitoring systems were launched with improved rack modules, notably the MPC4^{Mk2} + IOC4^{Mk2}, RLC16^{Mk2} and CPUM^{Mk2} + IOCN^{Mk2}. VM600^{Mk2} systems use the same system infrastructure as first-generation VM600 systems, that is, VM600^{Mk2} is backward compatible with existing VM600 (VM600^{Mk1}) racks and power supplies.

However, VM600^{Mk2} versions of the ABE040 system rack (PNR 200-040-100-016) and RPS6U rack power supplies (PNRs 200-582-200-12h, 200-582-500-12h and 200-582-600-12h) are also available. The VM600^{Mk2} versions are the same as the latest VM600 versions, except for the specific artwork/branding/finish. More specifically, the front panels of RPS6U rack power supplies are bare aluminium for the VM600^{Mk2} versions (PNRs 200-582-200-12h, 200-582-500-12h and 200-582-600-12h) and painted for the VM600 versions (PNRs 200-582-200-02h, 200-582-500-02h and 200-582-600-02h).

Environmental

Temperature

- Operating : 0 to 70°C (32 to 158°F)
- Storage : -40 to 85°C (-40 to 185°F)

Humidity : 5 to 90%, non-condensing
(according to IEC 60068-2-30)

Vibration : 10 to 55 Hz, 0.35 mm peak below resonance and 2 g peak above,
(according to IEC 60068-2-6) 6 hours/axis

Shock : 6 g peak, 11 ms, half-sine pulse, 3 shocks/axis
(according to IEC 60068-2-27)

Drop test : 30° drop angle
(according to IEC 60068-2-31)

MTBF : >40000 hours at 70°C (158°F)
(according to MIL-HDBK-217F)

Conformal coating : Applied to the circuitry of the power supply for additional
environmental protection against chemicals, dust, moisture and
temperature extremes

Indoor use : Limited to indoor use only

Approvals

Conformity : European Union (EU) declaration of conformity (CE marking).
EAC marking, Eurasian Customs Union (EACU) certificate/
declaration of conformity.

Electromagnetic compatibility : EN 55022 class "B".
FCC Docket 20780 curve "B".
IEC 61000-4-2: Performance criteria B, 4 kV contact discharge and
8 kV air discharge.
IEC 61000-4-3: Performance criteria A, 10V/m.
IEC 61000-4-4: Performance criteria A, 2 kV 5/50 ns, 5 kHz, direct
IEC 61000-4-6: Performance criteria A, level 3
IEC 61000-4-8: Performance criteria A, 50 Hz/30 A/m
TR CU 020/2011.

Electrical safety : CSA/EN/UL 60950-1 second edition.
TR CU 004/2011.

Overvoltage category : OVC II

Vibration : IEC 60255-21-1 (Class 2)

Environmental management : RoHS compliant

Russian federal agency for technical : Pattern approval certificate OC.C.28.004.A N° 60224
regulation and metrology (Rosstandart)

SPECIFICATIONS *(continued)*

Status indicators (LEDs)

IN	: Green indicates that the external mains supply is present and is within the normal range. See Mechanical drawings – VM600Mk2 versions on page 7 and Mechanical drawings – VM600 versions on page 8 .
+5V	: Yellow indicates that the +5 V _{DC} supply is being generated and is within the normal range
+12V	: Yellow indicates that the +12 V _{DC} supply is being generated and is within the normal range
-12V	: Yellow indicates that the -12 V _{DC} supply is being generated and is within the normal range

Connectors

Rear	: Two high-current DIN 41612 type H15 connectors. Sharing of power supply voltages and signals via the VM600 ^{Mk2} /VM600 rack backplane (ABE04x).
------	--

Physical

Dimensions	: See Mechanical drawings – VM600Mk2 versions on page 7 and Mechanical drawings – VM600 versions on page 8
Weight	: 2.4 kg (5.3 lb) approx.

TOLERANCE TO INTERRUPTIONS IN THE MAINS SUPPLY

The table below shows the maximum permissible duration of an interruption (cut) to the external AC or DC mains supply used as the input voltage to an RPS6U rack power supply. The maximum duration values depend on the maximum combination load for the RPS6U rack power supply, the number of RPS6U rack power supplies installed in the rack and the number of modules (cards) installed in the VM600^{Mk2}/VM600 rack (the actual load). If an interruption lasts longer than the maximum permissible duration, then the VM600^{Mk2}/VM600 modules (cards) installed in the rack may reset.

	Maximum duration of interruption to the supply input (ms)	
	At 10% of combination load	At 100% of combination load
One RPS6U AC rack power supply in the rack	190	10
Two RPS6U AC rack power supplies in the rack	250	20
One RPS6U 24 DC rack power supply in the rack	75	7
Two RPS6U 24 DC rack power supplies in the rack	150	14
One RPS6U 110 DC rack power supply in the rack	190	10
Two RPS6U 110 DC rack power supplies in the rack	250	20

ASSOCIATED REAR PANELS

(a) Standard DC version (ordering number (PNR): 200-582-920-NHh)

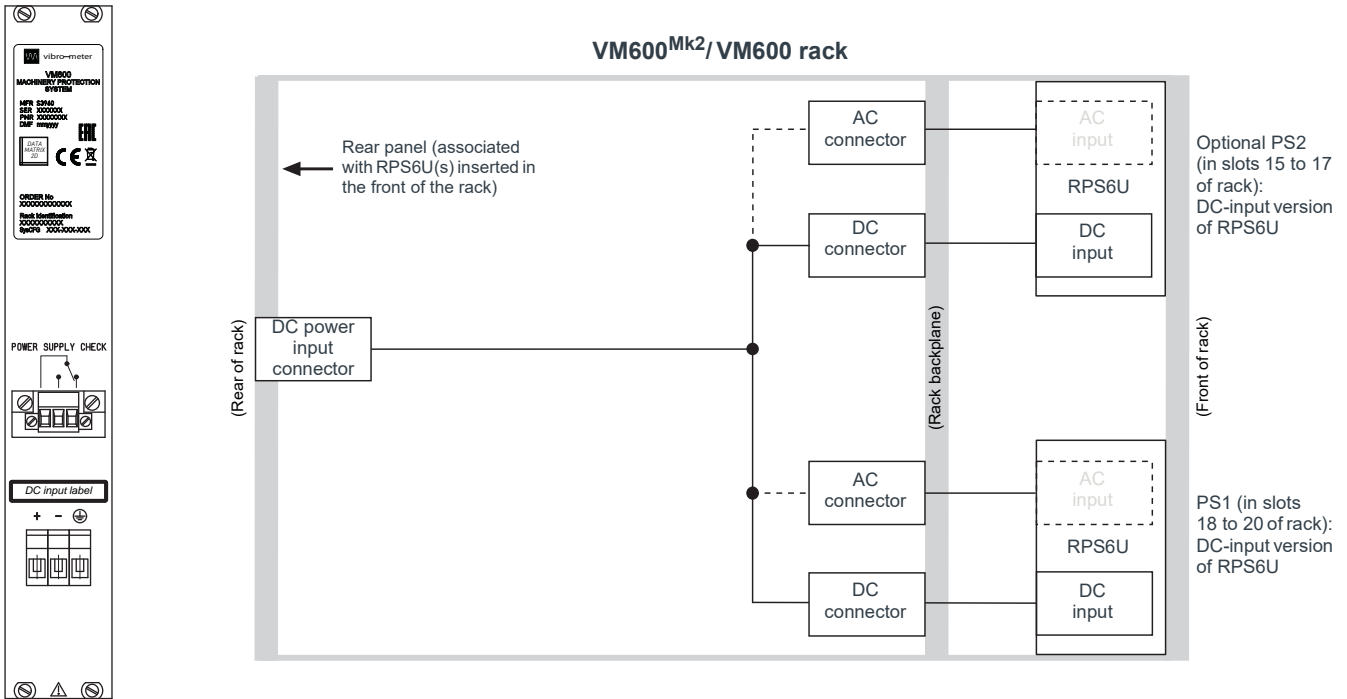

The wiring assembly for the rear panel includes the additional cabling (----) only when both RPS6U rack power supplies (PS1 and PS2) are AC-input versions operating with DC inputs (which requires a rear panel with a DC input).

(b) DC version (ordering number (PNR): 200-582-993-NHh)

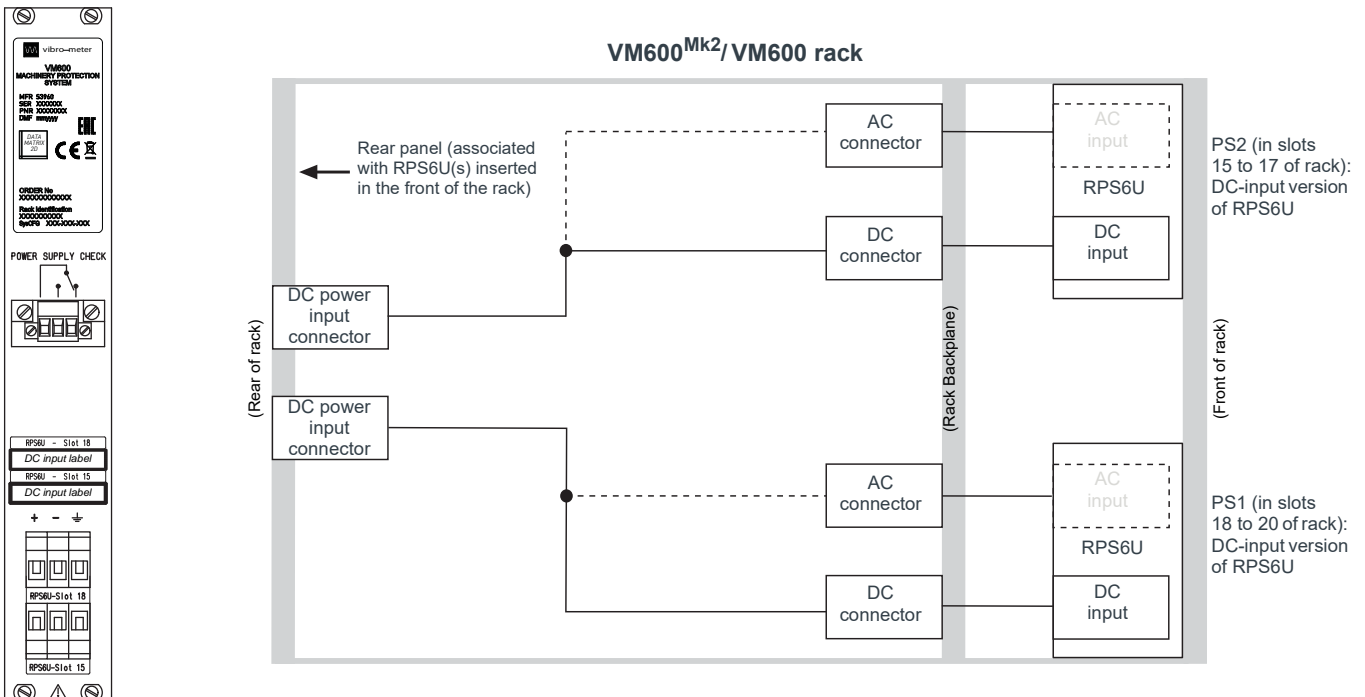

This version has two screw-terminal connectors for the DC power inputs, and individual inputs on each RPS6U. The wiring assembly for the rear panel includes the additional cabling (----) only when at least the first RPS6U rack power supply (PS1) is an AC-input version operating with a DC input (which requires a rear panel with a DC input).

ASSOCIATED REAR PANELS (continued)

(c) DC version with earth terminal (ordering number (PNR): 200-582-922-NHh)

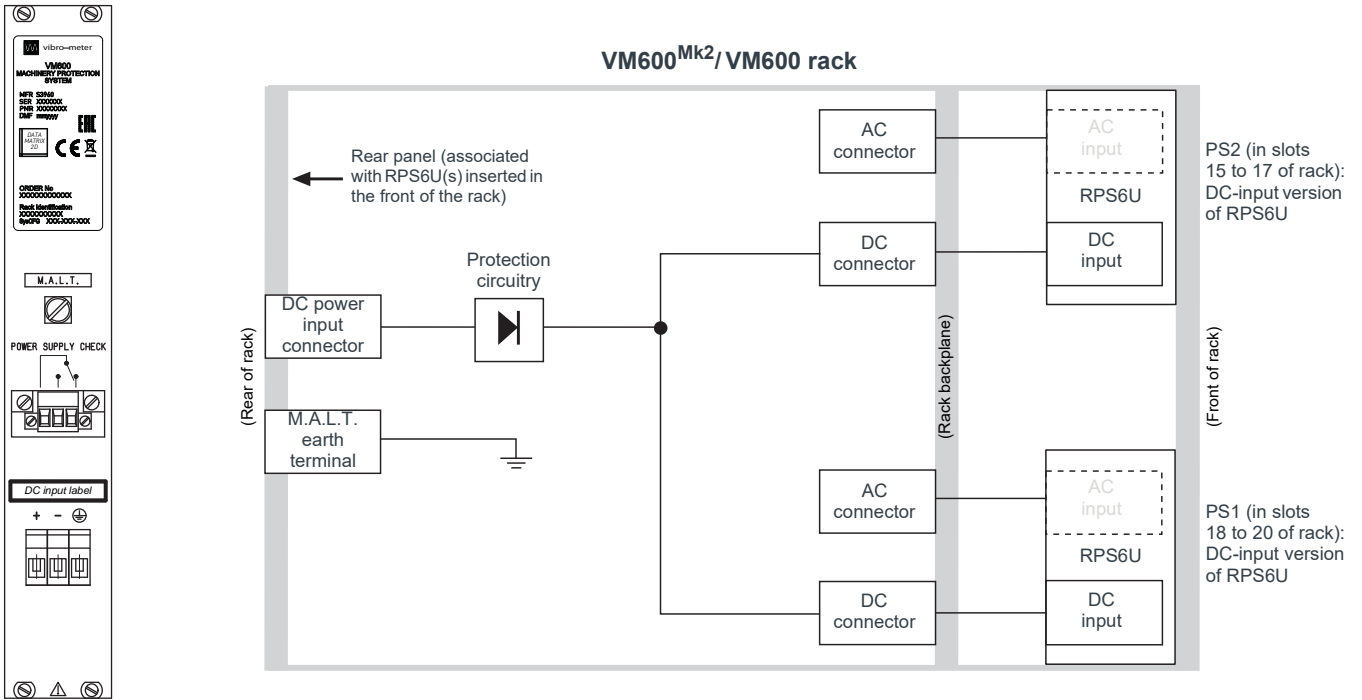

This version has a screw-terminal connector for the DC power input and a special earth terminal (identified as M.A.L.T.).

(d) Special DC version (ordering number (PNR): 200-582-990-NHh)

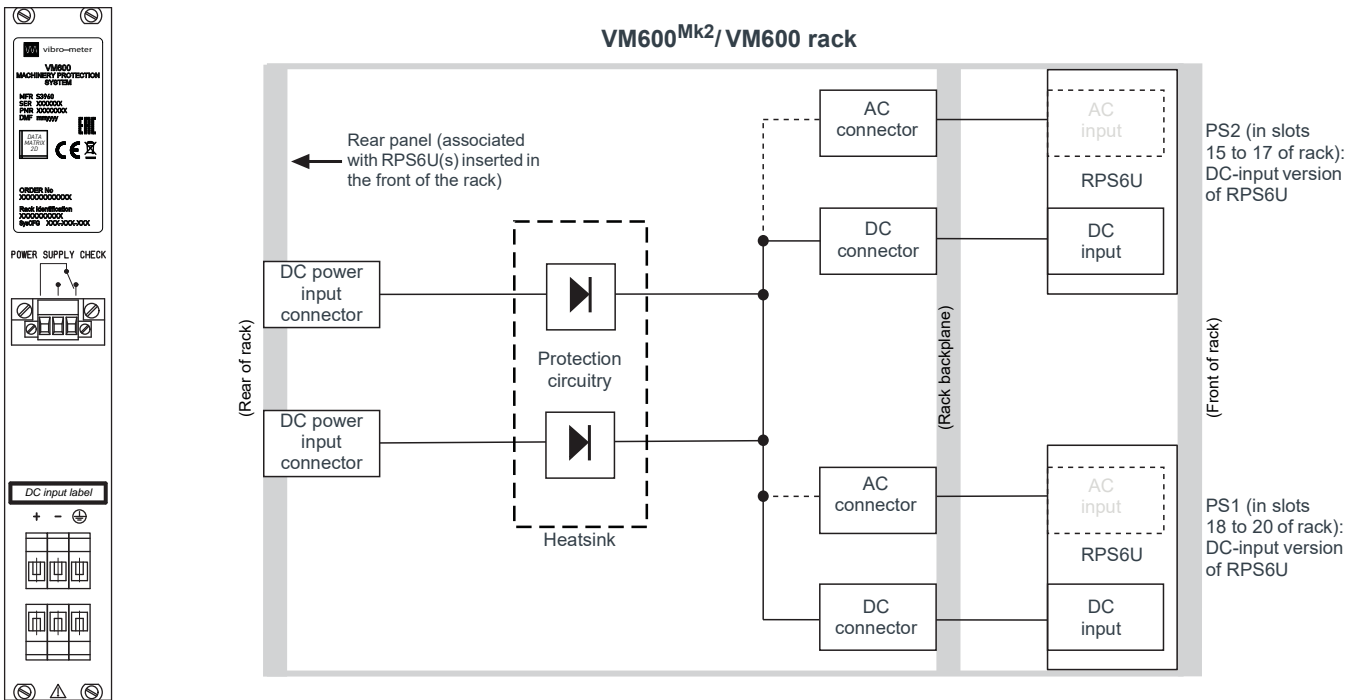

This version has two screw-terminal connectors for the DC power inputs, intended for the connection of two independent DC mains supplies. Both inputs (connectors) are wired to the same point on the VM600^{Mk2}/VM600 rack backplane through protection diodes, which allows the rack to continue operating if one of the DC mains supplies becomes defective. The wiring assembly for the rear panel includes the additional cabling (----) only when both RPS6U rack power supplies (PS1 and PS2) are AC-input versions operating with DC inputs (which requires a rear panel with a DC input).

ASSOCIATED REAR PANELS (continued)

(e) Standard AC version (ordering number (PNR): 200-582-910-NHh)

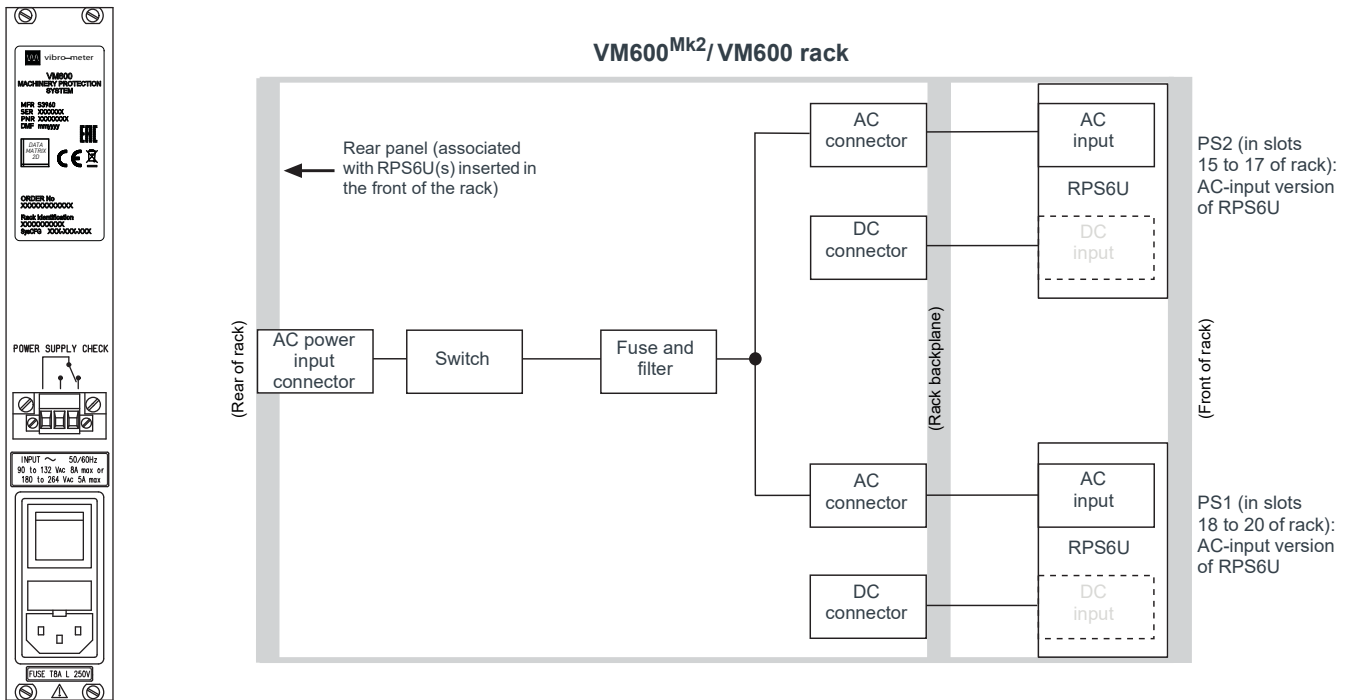

(f) AC version (ordering number (PNR): 200-582-911-NHh)

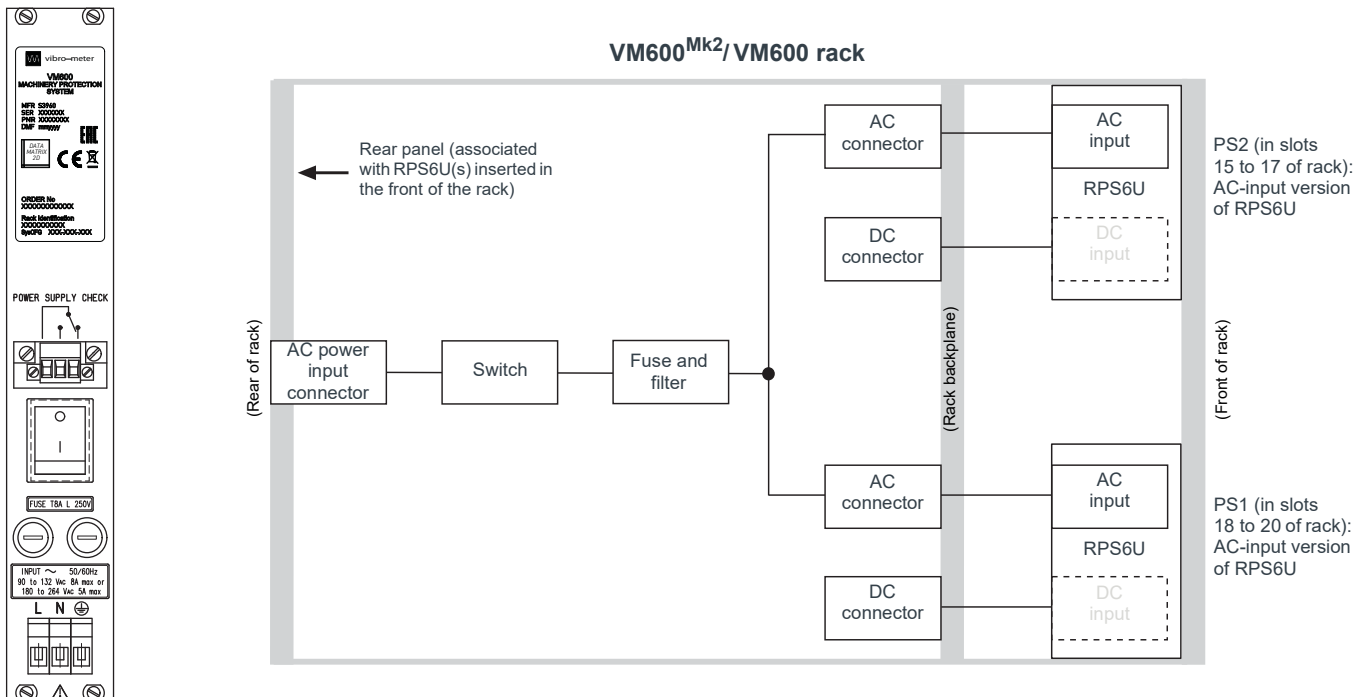

This version has a screw-terminal connector for the AC power input and a mains switch.

ASSOCIATED REAR PANELS (continued)

(g) AC version (ordering number (PNR): 200-582-912-NHh)

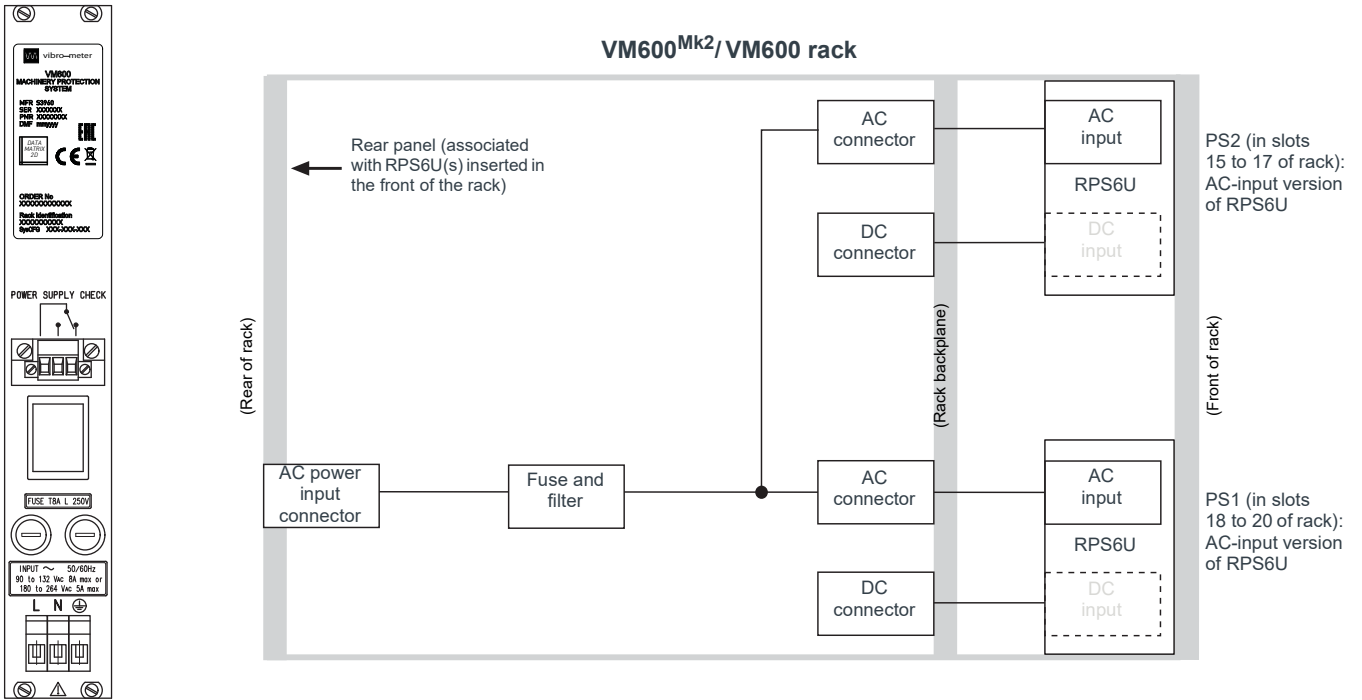

This version has a screw-terminal connector for the AC power input, but no mains switch.

(h) AC version (ordering number (PNR): 200-582-962-NHh)

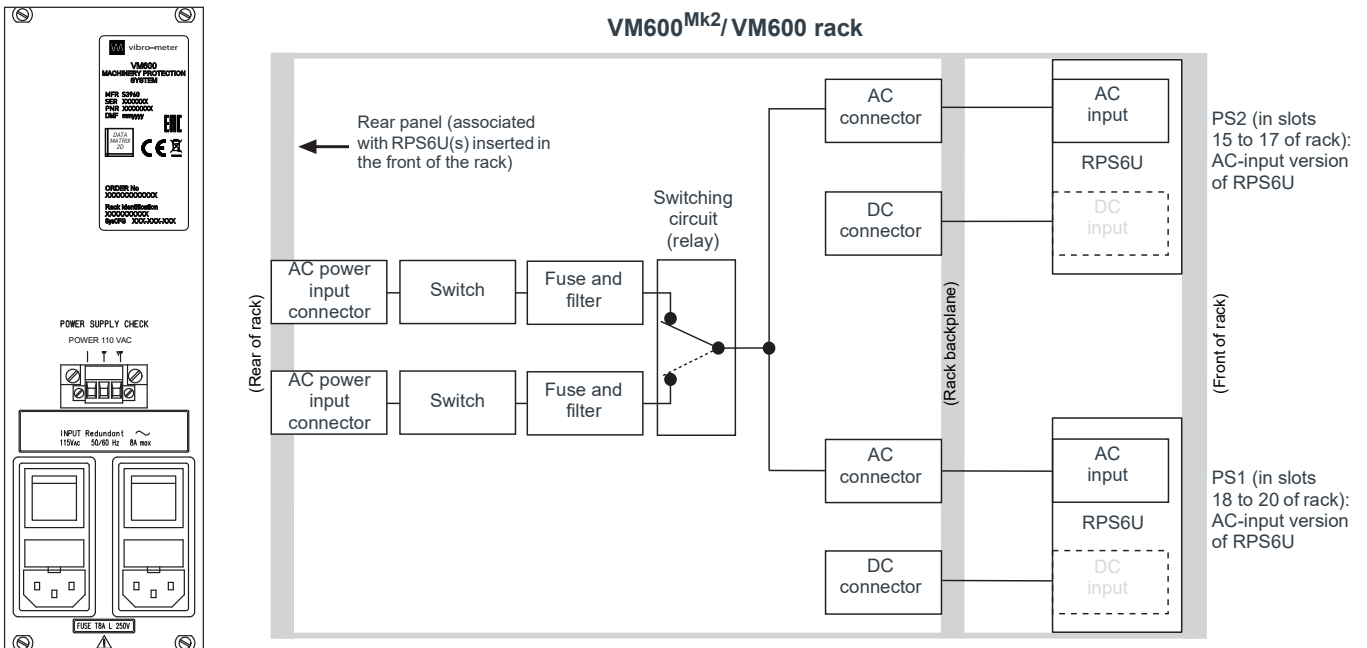

This version has two AC sockets, intended for the connection of two independent AC mains supplies operating at 120 V_{AC}. Both sockets are independently wired to a switching circuit on the VM600^{Mk2}/VM600 rack backplane. The rack is normally powered by the PS1 AC mains supply. If this supply becomes defective, the switching circuit allows operation to continue automatically with the PS2 AC mains supply.

ASSOCIATED REAR PANELS (continued)

(i) AC version (ordering number (PNR): 200-582-963-NHh)

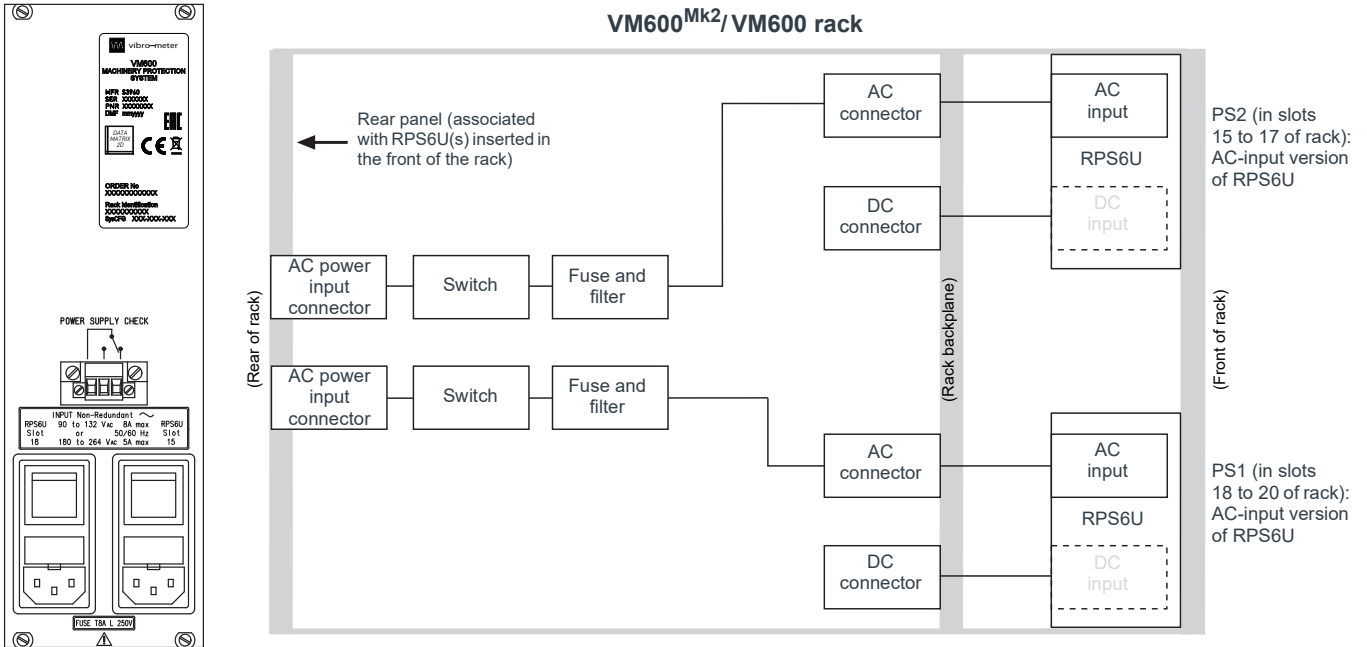

This version has two AC mains connectors and individual outputs to each RPS6U.

(j) AC version (ordering number (PNR): 200-582-960-NHh)

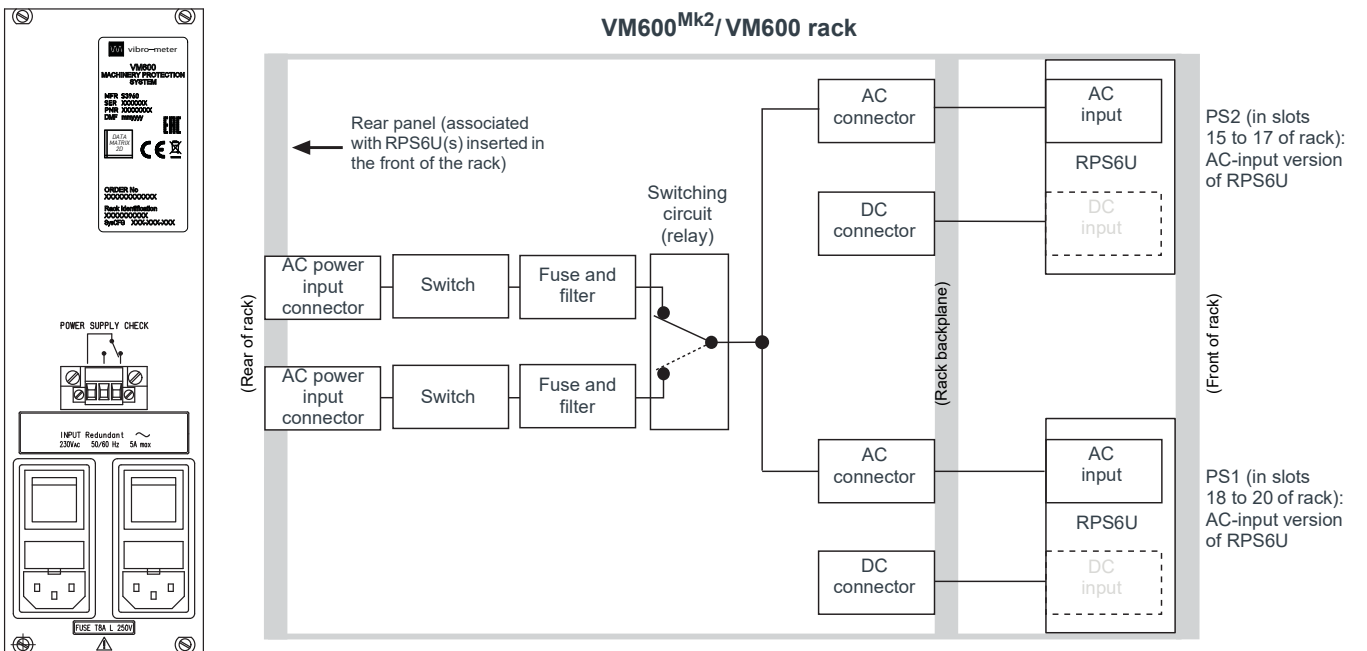

This version has two AC sockets, intended for the connection of two independent AC mains supplies operating at 230 V_{AC}. Both sockets are independently wired to a switching circuit on the VM600^{Mk2}/VM600 rack backplane. The rack is normally powered by the PS1 AC mains supply. If this supply becomes defective, the switching circuit allows operation to continue automatically with the PS2 AC mains supply.

ASSOCIATED REAR PANELS (continued)

(k) Special AC version (ordering number (PNR): 200-582-915-NHh)

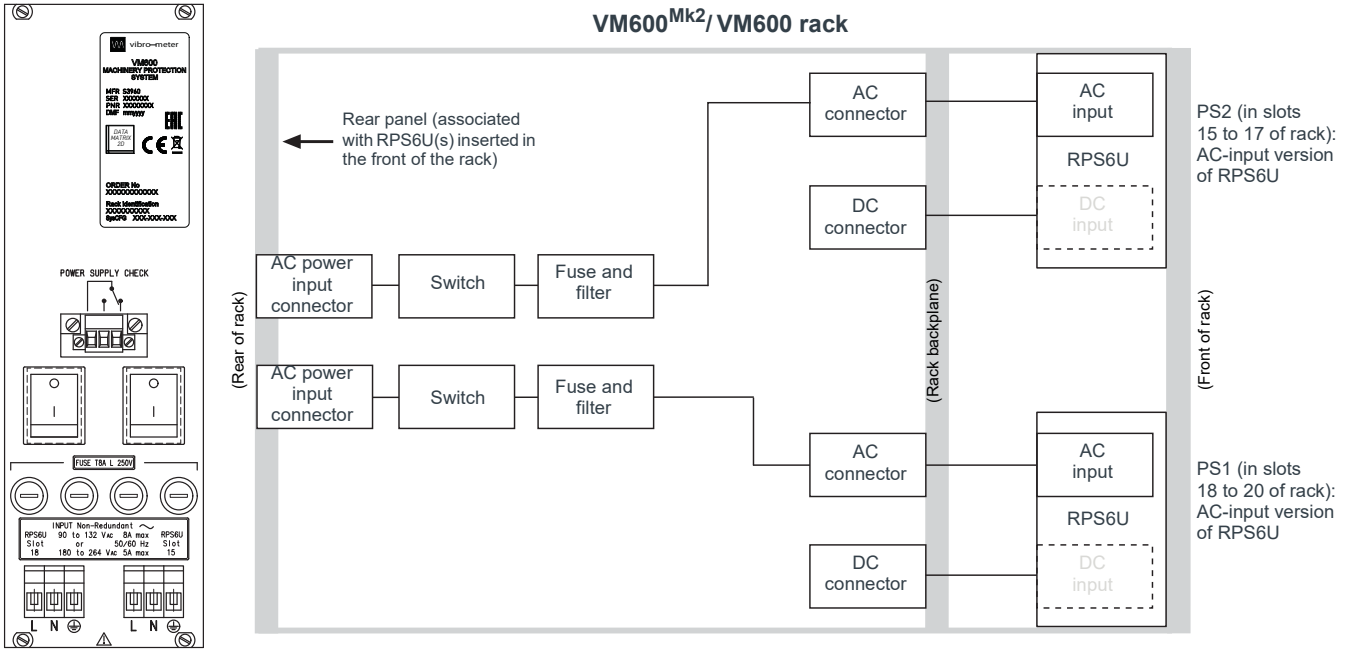

This version has two screw-terminal connectors for the AC power input and individual outputs to mains switches.

(l) Special AC version (ordering number (PNR): 200-582-916-NHh)

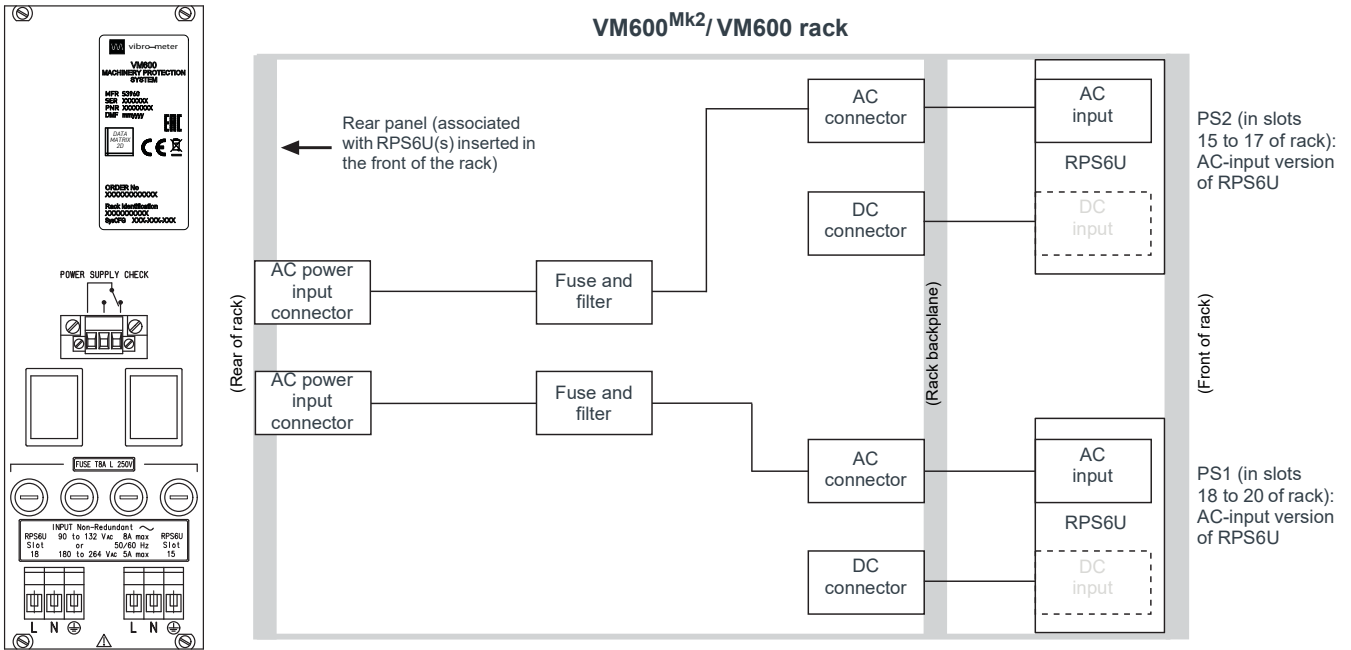

This version has two screw-terminal connectors for the AC power input and individual outputs, but no mains switches.

ASSOCIATED REAR PANELS *(continued)*

(m) Special AC and DC version (ordering number (PNR): 200-582-970-NHh)

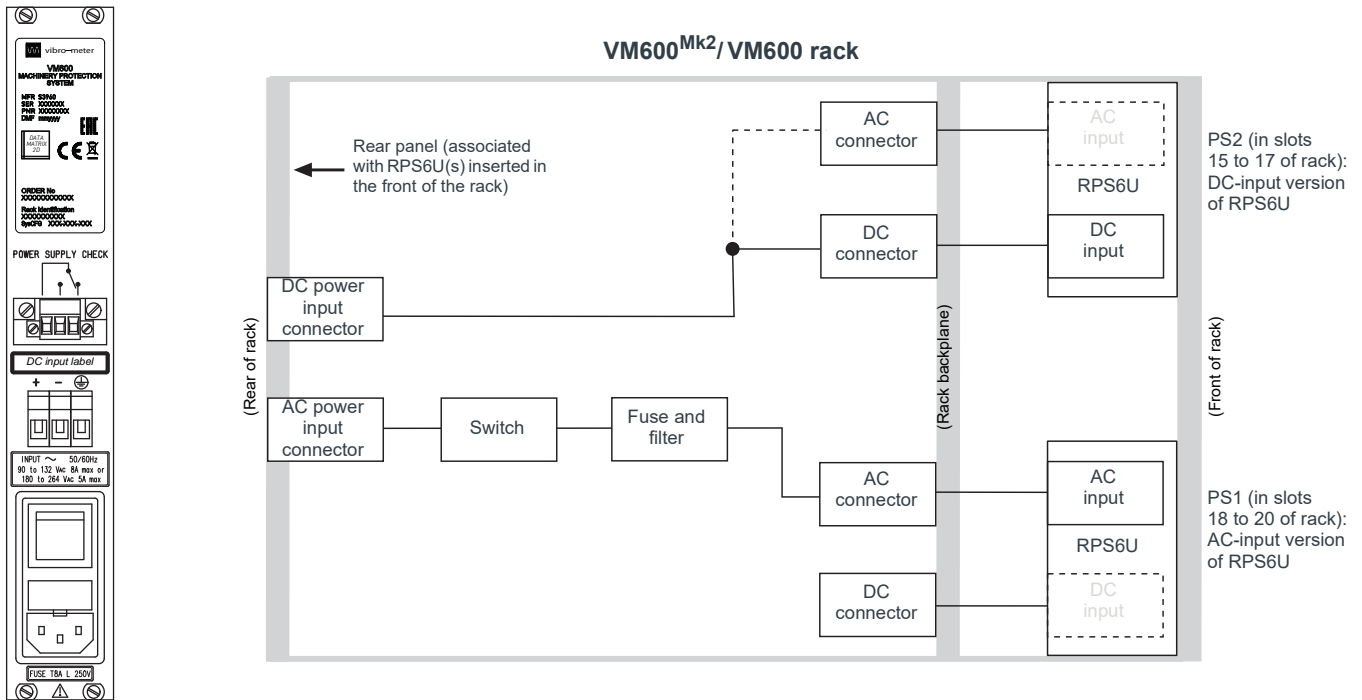

This version has an AC socket and a DC screw-terminal connector, intended for the connection of two independent mains supplies. These are wired separately to the VM600^{Mk2}/VM600 rack backplane's AC and DC inputs, respectively. This allows the rack to continue operating if one of the mains supplies becomes defective.

The wiring assembly for the rear panel includes the additional cabling (----) only when both RPS6U rack power supplies (PS1 and PS2) are AC-input versions operating with DC inputs (which requires a rear panel with a DC input).

ORDERING INFORMATION

RPS6U rack power supply

To order, specify a type (**RPS6U rack power supply**), designation and ordering number (PNR) from the table below.

Designation	AC-input version	DC-input versions	
	RPS6U AC	RPS6U 24 DC	RPS6U 110 DC
Ordering number See notes 1 and 2 below	200-582-500-12h (VM600 ^{Mk2}) or 200-582-500-02h (VM600)	200-582-200-12h (VM600 ^{Mk2}) or 200-582-200-02h (VM600)	200-582-600-12h (VM600 ^{Mk2}) or 200-582-600-02h (VM600)
Nominal input (line) voltage See note 3 below	115/230 V _{AC} or 220 V _{DC}	24 V _{DC}	110 V _{DC}

Notes

- "h" represents the hardware version. "h" increments are for minor modifications with no effect on product interchangeability.
- In 2021, VM600^{Mk2} (second-generation) machinery monitoring systems were launched with improved rack modules, notably the MPC4^{Mk2} + IOC4^{Mk2}, RLC16^{Mk2} and CPUM^{Mk2} + IOCN^{Mk2}. VM600^{Mk2} systems use the same system infrastructure as first-generation VM600 systems, that is, VM600^{Mk2} is backward compatible with existing VM600 (VM600^{Mk1}) racks and power supplies. However, VM600^{Mk2} versions of the ABE040 system rack (PNR 200-040-100-016) and RPS6U rack power supplies (PNRs 200-582-200-12h, 200-582-500-12h and 200-582-600-12h) are also available. In general, the VM600^{Mk2} versions are the same as the latest VM600 versions, except for VM600^{Mk2} specific artwork/branding/finish. More specifically, the front panels of RPS6U rack power supplies are bare aluminium for the VM600^{Mk2} versions (PNRs 200-582-200-12h, 200-582-500-12h and 200-582-600-12h) and painted for the VM600 versions (PNRs 200-582-200-02h, 200-582-500-02h and 200-582-600-02h).
- The AC-input version of the RPS6U rack power supply can also operate with a 178 to 264 V_{DC} input when used with the following rear panels with a DC input: 200-582-920-NHh, 200-582-993-NHh, 200-582-990-NHh or 200-582-970-NHh.

VM600^{Mk2}/VM600 system considerations – rack power supplies and modules (cards)

The maximum number of modules (cards) that can be installed in a VM600^{Mk2}/VM600 ABE04x system rack depends on the following RPS6U power supply considerations:

- Number of RPS6U power supplies installed in the rack: one or two.
- Power capability of the RPS6U power supplies installed in the rack: 330 or 300 W.
- With two RPS6U power supplies installed in the rack, the mode of operation of the RPS6U supplies: redundant or non-redundant.
- The operating temperature of the environment where the VM600^{Mk2}/VM600 rack is installed: RPS6U power supplies require either output power derating and/or forced-air cooling for operating temperatures of 50°C (122°F) or higher.

The maximum number of modules (cards) that can be installed in a VM600^{Mk2}/VM600 ABE04x system rack also depends on individual VM600^{Mk2}/VM600 module (card) considerations, for example, the configuration of sensor power supplies and DC outputs for MPC4^{Mk2} + IOC4^{Mk2} or MPC4/IOC4T.

In general, a VM600^{Mk2}/VM600 ABE04x system rack can have either one or two RPS6U power supplies installed, as follows:

- One RPS6U (330 W) operating non-redundantly (that is, without rack power supply redundancy) in order to support a full rack of modules (cards), for operating temperatures up to 50°C (122°F).
- Two RPS6Us (330 W) operating redundantly (that is, with rack power supply redundancy) in order to support a full rack of modules (cards), for operating temperatures up to 50°C (122°F).

Note: When two RPS6U rack power supplies operate redundantly to supply power to the modules (cards) in a VM600^{Mk2}/VM600 rack, the maximum current available for use is limited to the current available from a single RPS6U power supply.

- Two RPS6Us (330 W) operating non-redundantly (that is, without rack power supply redundancy) in order to support any combination of modules (cards) under all circumstances, notably operating temperatures up to 70°C (158°F).

Note: When two RPS6U rack power supplies operate non-redundantly to supply power to the modules (cards) in a VM600^{Mk2}/VM600 ABE04x system rack, the maximum current available for use is limited to approximately 125% (× 1.25) the current available from a single RPS6U because of the way in which the power supplies share the load. The current load is shared between the two RPS6U power supplies with a maximum ratio of 20 to 80%.

A VM600^{Mk2}/VM600 ABE04x system rack with two RPS6U power supplies (330 W) operating non-redundantly is typically only necessary for a full rack of modules (cards) in applications where the operating environment requires RPS6U output power derating. For a VM600^{Mk2}/VM600 rack configuration that contains more than ten processing modules (cards) (MPC4^{Mk2} + IOC4^{Mk2} or MPC4/IOC4T, AMC8/IOC8T card and/or XMx16/XIO16T) together with a CPUM^{Mk2} + IOCN^{Mk2} or CPUx/IOCx "rack controller" and/or RLC16^{Mk2} or RLC16 relay cards, the power consumption of the rack should be calculated in order to determine the number of RPS6U power supplies required and the permitted modes of operation.

VM600^{Mk2}/VM600 system considerations – electrical circuit protection

The maximum input current specified for the different versions of the RPS6U rack power supply in the specifications on page 3 should be used to help specify suitable electrical circuit protection for a VM600^{Mk2}/VM600 ABE04x system rack:

- For the AC-input version of the RPS6U power supply, the associated rear panels include appropriately rated fuses for the AC inputs.
- For the DC-input versions of the RPS6U power supply, the associated rear panels do not include electrical circuit protection for the DC inputs, so an appropriately rated external circuit breaker or equivalent must be used.

ORDERING INFORMATION *(continued)*

Associated rear panels

To order please specify a type (Rear panel), designation and ordering number (PNR) from the table below. (See also the drawings (a) to (k) in associated rear panels on page 9 on pages 4 to 9.)

Drawing	Designation	Ordering number (PNR)	Equivalent VM600SYS... order option codes	
			VM600SYSMK2	VM600SYS
(a)	One DC input with screw-terminal connector that provides a common input to the RPS6U rack power supplies	200-582-920-NHh	F920	F200
(b)	Two DC inputs with screw-terminal connectors that provide individual inputs to the RPS6U rack power supplies	200-582-993-NHh	F993	F930
(c)	One DC input with screw-terminal connector that provides a common input to the RPS6U rack power supplies. Also provides a special earth terminal (identified as M.A.L.T.).	200-582-922-NHh	F922	F220
(d)	Two DC inputs with screw-terminal connectors that provide a common input to the RPS6U rack power supplies. Note: Supports redundant external power-supply systems.	200-582-990-NHh	F990	F900
(e)	One AC input (120/230 V _{AC}) with mains socket, on/off switch, fuse and filter that provides a common input to the RPS6U rack power supplies	200-582-910-NHh	F910	F100
(f)	One AC input (120/230 V _{AC}) with screw-terminal connector, on/off switch, fuse and filter that provides a common input to the RPS6U rack power supplies	200-582-911-NHh	F911	F110
(g)	One AC input (120/230 V _{AC}) with screw-terminal connector, fuse and filter that provides a common input to the RPS6U rack power supplies	200-582-912-NHh	F912	F120
(h)	Two AC inputs (120 V _{AC} only) with mains sockets, on/off switches, fuses and filters that provide a common input to the RPS6U rack power supplies. Note: Supports redundant external power-supply systems.	200-582-962-NHh	F962	F620
(i)	Two AC inputs (120/230 V _{AC}) with mains sockets, on/off switches, fuses and filters that provide individual inputs to the RPS6U rack power supplies	200-582-963-NHh	F963	F630
(j)	Two AC inputs (230 V _{AC} only) with mains sockets, on/off switches, fuses and filters that provide a common input to the RPS6U rack power supplies. Note: Supports redundant external power-supply systems.	200-582-960-NHh	F960	F600
(k)	Two AC inputs (120/230 V _{AC}) with screw-terminal connectors, on/off switches, fuses and filters that provide individual inputs to the RPS6U rack power supplies	200-582-915-NHh	F915	F150
(l)	Two AC inputs (120/230 V _{AC}) with screw-terminal connectors, fuses and filters that provide individual inputs to the RPS6U rack power supplies	200-582-916-NHh	F916	F160
(m)	One AC input (120/230 V _{AC}) with mains socket, on/off switch, fuse and filter, and one DC input with screw-terminal connector that provide individual inputs to the RPS6U rack power supplies	200-582-970-NHh	F970	F700

(See Notes on the next page ...)

ORDERING INFORMATION *(continued)*

Notes (for Associated rear panels)

All rear panels – (a), (b), (c), (d), (e), (f), (g), (h), (i), (j), (k), (l) and (m) – are available as a “standard” version suitable for European and international markets.

All AC-input rear panels – (e), (f), (g), (h), (i), (j), (k), (l) and (m) – are available as an “ASPS” version suitable for use with the VM600^{Mk2}/VM600 ASPS auxiliary sensor power supply.

Some AC-input and DC-input rear panels – (a), (d), (e) and (h) – are available as a “CSA” version suitable for North American and international markets.

All DC-input rear panels – (a), (b), (c), (d) and (m) – do not include electrical circuit protection for the DC inputs, so an appropriately rated external circuit breaker or equivalent must be used.

All AC-input rear panels – (e), (f), (g), (h), (i), (j), (k), (l) and (m) – include appropriately rated fuses for the AC inputs.

The rear panels – (d), (h) and (j) – with two input connectors that provide a common input to the RPS6U rack power supplies installed in the VM600^{Mk2}/VM600 rack support external mains power-supply system redundancy.

All AC-input rear panels – (e), (f), (g), (h), (i), (j), (k), (l) and (m) – are supplied with a mains power supply lead (no lead is supplied for the DC-input versions). See **Mains power supply leads (power cords) on page 18**.

AC-input rear panels with mains sockets have an IEC type C14 connector (IEC 60320) that mates with the plug (type C13) used by the supplied mains power supply leads.

Some rear panels – (a), (b), (c), (d), (e), (f), (g) and (m) – are 2 slots wide / 8 HP (TE).

Other rear panels – (h), (i), (j), (k) and (l) – are 4 slots wide / 16 HP (TE).

(The width of a 19” rack is measured in horizontal pitch (HP) units of 5.08 mm (0.2”), also known as standard width (TE) units. For the ABE04x rack, a one slot wide (one card position) blank panel corresponds to 4 HP (TE), a two slot wide blank panel corresponds to 8 HP (TE) and a four slot wide blank panel corresponds to 16 HP (TE).)

For the Ordering number (PNR), “NHh” represents the hardware version as follows:

“N” is either “0” for the “standard” version of a rear panel (certified and marked “CE”) or “2” for the “CSA” version of a rear panel (certified and marked “cCSAus”).

“H” increments are for major modifications that can affect product interchangeability.

“h” increments are for minor modifications that have no effect on interchangeability.

Mains power supply leads (power cords)

To order please specify a type (mains power supply lead), designation and ordering number (PNR) from the table below.

Designation	Ordering number (PNR)	Equivalent VM600SYS order option code
None – no mains cable	---	H00
No plug – flying lead with wire-end ferrules	957.18.13.0020	H01
J plug as per SEV 1011 (Switzerland)	957.18.13.0021	HCH
E+F plug as per CEE7/VII (Europe, Russia, Ukraine)	957.18.13.0022	HEU
G plug as per BS 1363 (UK, Hong Kong, Malaysia, Singapore)	957.18.13.0023	HUK
B plug as per JIS 8303 (Japan)	957.18.13.0024	HJP
B plug as per NEMA 5-15 (United States, Canada)	957.18.13.0025	HUS

Notes

The mains cables (power cords) are for use with the AC-input version of the RPS6U rack power supply only. No cables are available for the DC-input versions of the RPS6U rack power supply.

Associated rear panels with two AC inputs for independent mains supplies (ordering numbers (PNRs): 200-582-96x-NHh) require two mains cables.

ORDERING GUIDELINES

The ordering numbers (PNRs) given in **Ordering information starting on page 16** of this data sheet should be used when ordering a VM600^{Mk2}/VM600 RPS6U rack power supply, associated rear panels and/or mains power supply leads (power cords) as individual system components for use as a replacement or spare part. However, when ordering these components with other system components as part of a complete VM600^{Mk2}/VM600 machinery monitoring system, then a VM600SYS-based ordering number should be used. Contact your local Meggitt representative for further information.

RELATED PRODUCTS

VM600^{Mk2} (second generation)

ABE04x	VM600 ^{Mk2} /VM600 system racks	: Refer to corresponding data sheet
ABE056	VM600 ^{Mk2} /VM600 slimline rack	: Refer to corresponding data sheet
ASPS	VM600 ^{Mk2} /VM600 auxiliary sensor power supply	: Refer to corresponding data sheet

VM600 (first generation)

ABE04x	VM600 ^{Mk2} /VM600 system racks	: Refer to corresponding data sheet
ABE056	VM600 ^{Mk2} /VM600 slimline rack	: Refer to corresponding data sheet
ASPS	VM600 ^{Mk2} /VM600 auxiliary sensor power supply	: Refer to corresponding data sheet