

Company: Joyoung International Trading Co., Limited

Atten: Smiling

Mobile/WhatsApp/Wechat: +86 18050035902

Email: info@htechplc.com

Website: <https://www.joyoungintl.com/>



GE

Grid Solutions

Multilin 350

Intuitive and Innovative Feeder Protection

The Multilin™ 350 is a member of the Multilin 3 Series protective relay platform and has been designed for the protection, control and management of feeders or related applications as a primary or backup protection device. This cost-effective protective device is used to perform advanced feeder protection, control and monitoring in a drawout or non-drawout design for low, medium and high voltage applications. The 350 also offers enhanced features such as metering, monitoring and diagnostics, preventative maintenance, advanced communications and security.

Key Benefits

- Cost-effective and flexible protection and control for utility and industrial applications
- Field-proven algorithms and reliable protection to avoid unwanted trips or under-protection
- Ease of use and standardization with one-step setup and universal CT inputs
- Environmental monitoring system to monitor operating conditions and plan preventative maintenance
- Advanced power system and switchgear diagnostics
- Flexible communications with multiple ports and protocols allowing seamless integration
- Arc flash mitigation via zone inter-tripping, flex curves and multiple elements and setting groups
- Powerful Security and hierarchical password control for centralized management
- Application flexibility with the use of programmable logic elements
- Drawout design simplifies, commissioning and maintenance, thereby increasing process uptime
- Increased network availability with zero failover time through IEC® 62439-3 PRP and HSR support
- Precise time synchronization through IEEE® 1588 (Precise Time Protocol (PTP)) support
- Robust design exceeding industry standards, with Automotive Grade components and advanced testing procedures such as accelerated life cycle testing
- Simplified migration of legacy MII Family relays to the 3 Series platform
- Intuitive configuration software and user-friendly logic configuration tool

Applications

- Primary protection and control for MV and HV utility and industrial overhead or cable feeder applications
- Protection for distribution transformers of various sizes and voltage levels
- Back-up protection for various HV applications
- Capacitor bank protection
- Advanced control applications including Cold Load Pickup, multi-shot recloser and multiple settings groups
- Protection, control and monitoring of LV Incoming feeder providing flexible communications and eliminating the need for auxiliary equipment
- Harsh environments requiring protection against corrosion and humidity



imagination at work

Protection and Control

- Comprehensive current, voltage and frequency protection functions
- Directional Power and Wattmetric Ground Fault
- Wide variety of protection curves
- Synchrocheck, CLP, 2nd Harmonic Blocking, Breaker Failure and Lockout functions

Metering and Monitoring

- Comprehensive metering
- Event Recorder: 256 events (1ms time stamping)
- Programmable oscillography up to 32 samples per cycle and digital states and Fault Report
- Relay health diagnostics
- Breaker monitoring and CT/VT supervision
- Security and password control
- SNTP, IRIG-B or IEEE 1588 time synchronization

Communications

- Front USB and rear serial, Ethernet, Fiber and dual port options for seamless redundancy (IEC 62439-3, PRP and HSR)
- Multiple communication protocols including IEC 61850, IEC 61850 GOOSE, Modbus™ TCP/IP, Modbus RTU, DNP 3.0, IEC 60870-5-104, IEC 60870-5-103 and OPC-UA (IEC 62541)

EnerVista™ Software

- Simplified setup and configuration
- Strong document management system
- Full featured monitoring and data recording
- Maintenance and troubleshooting tool
- Seamless integration toolkit
- Setting conversion tool for MII Family to 3 Series

Overview

The 350 relay is a member of the 3 Series family of Multilin relays. This protective device is used to perform primary or back-up circuit protection on medium or high voltage feeders or transformers and down stream protection for utility and industrial switchgear. The 350 can be used for a wide variety of protection applications in power systems such as HV/MV or MV/LV transformer protection or capacitor bank protection.

The basic protection provided by this relay includes multiple phase, ground, and neutral time and instantaneous overcurrent elements for coordination with upstream and downstream devices. Additionally, the device provides essential feeder control features such as cold load pick up blocking, 2nd harmonic blocking, breaker failure, synchrocheck and autoreclose.

The robust 350 streamlines user work flow processes and simplifies engineering tasks such as configuration, wiring, testing, commissioning and maintenance. This cost-effective relay also offers enhanced features such as diagnostics, preventative maintenance, arc flash mitigation and security.

Easy to Use

Drawout & Non-Drawout Construction

The 350 is offered in both a drawout or a non-drawout construction. In the drawout case design the 350 simplifies installation and improves site safety as the need to open switchgear doors or rewire the device after testing is eliminated. As communication cables remain connected to the chassis, even when the relay is withdrawn, communications status is retained.

Application Flexibility & Ease of Wiring

Removable terminals ease wiring and in-system testing or troubleshooting.

Available universal CT inputs along with a software-configurable input range (1A and/or 5A) helps to standardize the design and reduce the number of order codes. There is also no need to change the entire relay in case of a design change or future switchgear modifications. Mixed inputs of 1A or 5A are advantageous for applications where the ground CT is different from the phase CTs.

Fast and Simple Configuration

With quick setup screens the 350 requires minimal configuration for standard feeder applications. Utilizing the powerful EnerVista 3 Series setup software, device configuration can be completed in one easy step.

Advanced Communications

Easy Integration Into New or Existing Infrastructure

With several Ethernet and serial port options, and a variety of protocols, the 350 provides advanced and flexible communication selections for new and existing energy management, SCADA and DCS systems. The 350 also provides industry-leading protocols such as PRP and HSR, when a failover time in communications is not tolerated.

Enhanced Diagnostics

Preventative Maintenance

The 350 allows users to track relay exposure to extreme environmental conditions by monitoring and alarming at high ambient temperatures.

350 Relay Features



Easy to Configure- 1 Simple Step



Advanced & Flexible Communication Options



Non-drawout case design



Easy to Use - Drawout Case

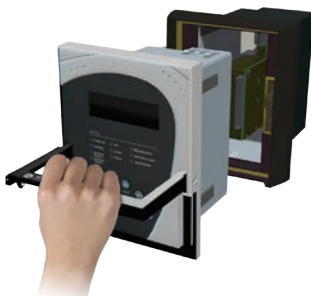

Diagnostic Alarms

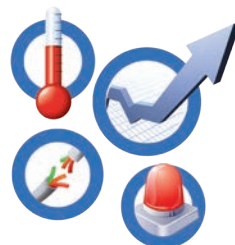

Drawout case design

Functional Block Diagram

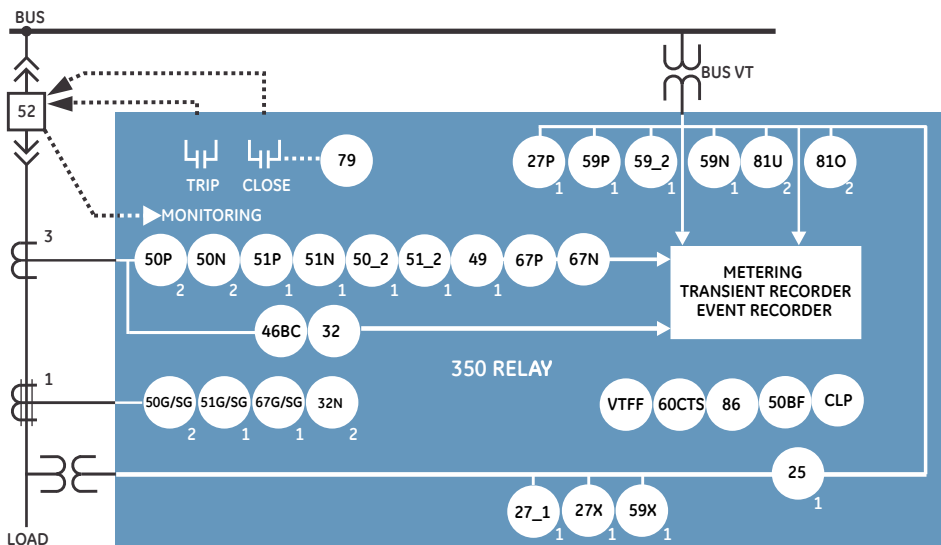

Protection

The 350 feeder protection system offers comprehensive fit-for-application protection with multiple elements.

Overcurrent (51P/N/G/SG/_2, 50P/N/G/SG/_2)

The 350 provides three-phase TOC elements including Phase, Neutral, Ground (or Sensitive Ground) and Negative Sequence which enable coordination with upstream and downstream protection devices such as fuses and overload relays, to maximize fault selectivity and minimize interruptions and downtime.

Multiple time current curves are available including IAC, IEC, ANSI and IEEE curves. Additional user-programmable flex curves can be used to customize and meet specific coordination requirements. The TOC has both linear and instantaneous reset timing functions to coordinate with electro-mechanical relays.

The instantaneous TOC element provides fast clearance of high magnitude faults to prevent damage to the power infrastructure and the equipment connected to it.

The neutral overcurrent TOC element is derived as the residual sum of the three-phase CTs, eliminating the need for an additional ground sensor. The sensitive ground protection feature detects ground faults on high impedance grounded systems in order to limit damage to conductors and equipment. Special low ratio CT's are used for detecting low magnitude ground faults.

Directional Overcurrent (67P, 67N, 67G/SG)

Directional elements determine the phase current flow direction for steady state and fault conditions and can be used to control the operation of the phase overcurrent elements by sending directional bits to inputs of these elements.

The Ground and Neutral Directional element is used to discriminate between faults occurring in a forward or in a reverse direction, and it can be used either individually or with other overcurrent elements to define the trip direction.

The directional ground overcurrent element isolates faulted feeders in ring bus or parallel feeder arrangements. It also allows the detection of back feed fault current from feeders with motors.

Broken Conductor (I1/I2 OR 46BC)

The Broken Conductor detection function detects a line broken conductor condition or

ANSI® Device Numbers & Functions

DEVICE NUMBER	61850 LOGICAL NODE	DESCRIPTION
25	RSYN	Synchrocheck
27_1	psseqPTUV	Positive Sequence Undervoltage
27P	phsPTU	Phase Undervoltage
27X	auxPTUV	Auxiliary Undervoltage
32	PDOP	Directional Power
32N	ndPDOP	Wattmetric Ground Fault
I1/I2 OR 46BC		Broken Conductor
49	PTTR	Thermal Overload
50_2	ngseqPIOC	Negative Sequence Overcurrent
50BF	RBRF	Breaker Failure
50G/SG	gndPIOC/hsePIOC	Ground (or Sensitive Ground) Instantaneous Overcurrent
50N	ndPIOC	Neutral Instantaneous Overcurrent
50P	phsPIOC	Phase Instantaneous Overcurrent
51_2	ngseqPTOC	Negative Sequence Time Overcurrent
51G/SG	gndPTOC/hsePTOC	Ground (or Sensitive Ground) Time Overcurrent

DEVICE NUMBER	61850 LOGICAL NODE	DESCRIPTION
51N	ndPTOC	Neutral Time Overcurrent
51P	phsPTOC	Phase Time Overcurrent
59_2	ngseqPTOV	Negative Sequence Overvoltage
59N	ndPTOV	Neutral Overvoltage
59P	phsPTOV	Phase Overvoltage
59X	auxPTOV	Auxiliary Overvoltage
60CTS		CT Supervision
67G/SG	gndRDIR	Ground (or Sensitive Ground) Directional Element
67N	ndRDIR	Neutral Directional Element
67P	phsRDIR	Phase Directional Element
79	RREC	Autoreclose
81O	PTOF	Overfrequency
81U	PTUF	Underfrequency
86		Lockout
CLP		Cold Load Pickup
VTF (60VTS)		Voltage Fuse Failure

This data allows proactive scheduling of regular maintenance work and upgrade activities. The diagnostics data enables the user to understand degradation of electronics due to extreme conditions.

Switchgear Diagnostics

The current and voltage transformer monitoring feature allows users to easily locate and troubleshoot potential failures or mis-operations caused by CTs or VTs. Trip/Close Circuit Monitoring provides constant monitoring of the health the control circuit.

Cost Effective

Robust Design and Reduced Life Cycle Cost

The 350 is subjected to Accelerated Life Testing

(ALT) to validate accurate relay function under specified normal conditions. The device is further tested for durability through Highly Accelerated Life Testing (HALT) where it undergoes extreme operating conditions. The robust 350 design along with drawout construction ensures long term operation and reduces the total installation, maintenance and life cycle cost of the protection system, thereby reducing downtime and associated costs.

Fit-for-Purpose Options

Several options for protection, control and communications are provided to match basic to high end application requirements.

The variety of order code selections satisfies the need for various applications from single-function Current or Voltage protection to multi-function including Power and Directional elements.

a single-pole breaker malfunction condition through checking the phase current input phasors and the I₂ / I₁ ratio.

Voltage and Frequency Protection (27P/X/_1, 59P/59X/N/_2, 81O/U)

Overvoltage and Undervoltage elements provide protection for voltage sensitive equipment as well as control for permissive functions and source transfer schemes.

Overfrequency and underfrequency elements improve network (grid) stability using voltage or frequency based load shedding techniques.

These elements also provide back up protection when protecting feeders and other frequency sensitive power equipment.

Thermal Overload (49)

The thermal overload protection function can be applied to prevent damage to the protected cables, dry transformers, capacitor banks, or even overhead lines. Loads exceeding the load ratings of the protected equipment can, over time, degrade the insulation, and may, in return, lead to short circuit conditions.

This protection feature is essential to ensure the longevity of electrical equipment; particularly important to prevent premature cable failures, expensive repair costs and system down time.

Directional Power (32)

Directional Power, with two independent elements, corresponds to three-phase directional power and is designed for applications requiring reverse power or low forward power.

Wattmetric Ground (32N)

The Wattmetric ground fault element detects feeder/line ground faults in solidly grounded, resistance grounded, ungrounded and resonance grounded networks.

It responds to power derived from zero-sequence voltage and current in a direction specified by the element characteristic angle.

Control

Synchronism Check

The Synchrocheck element monitors the connection of two parts of the circuit by the close of a breaker. This element verifies that voltages on both sides of the breaker are within the magnitude, angle and frequency limits set by the user before closing the breaker, in order to minimize internal damage that could occur due to the voltage difference.

Cold Load Pick Up (CLP)

Cold Load Pick up allows automatic or manual blocking or raising of trip settings for a period after the breaker has been closed. This feature adapts the pick up of overcurrent elements to override the higher overload currents resulting from re-energization of the feeder after a certain period of time.

Second-Harmonic Blocking

The second-harmonic blocking element ensures that the protection function will not pick up in the event of transformer start-up, or when CTs are becoming saturated.

Breaker Failure

The Breaker Failure function is used to determine when a trip command sent to a breaker has not been executed within a selectable time delay. In the event of a breaker failure, the 350 will issue an additional signal to trip the breakers connected to the same busbar or to signal the trip of upstream breakers.

Autoreclose

Reclose can be initiated externally or from an overcurrent protection function. Up to four reclose operations are available, each with a programmable dead time. For each reclose shot, the relay can be programmed to block any overcurrent element.

VT and CT Supervision

The CT failure function is designed to detect problems with switchgear current transformers.

Failure of a CT secondary wiring that is open (one phase or two phases), can lead to undesired operation by some of the enabled protection elements. VT fuse failure is used to detect various VT failure modes.

Lockout

The purpose of the Lockout function is to prevent unwanted closing of the breaker after being tripped by the operation of a protection element. A dedicated lockout function with ten individual inputs is available.

Automation and Integration

Inputs and Outputs

The 350 features the following inputs and outputs for monitoring and control of typical feeder applications:

- 10 contact Inputs with programmable thresholds
- 2 Form A outputs for breaker trip and close with coil monitoring and 5 Form C output relays

IEC 61850 GOOSE

The 350 supports IEC 61850 which allows for digital communications to DCS, SCADA and higher level control systems. In addition, the 350 also supports IEC 61850 GOOSE communication, providing a means of sharing digital point state information between several 350 relays or other IEC 61850 compliant IEDs.

- Eliminates the need for hardwiring contact inputs to contact outputs via communication messaging.

Logic Designer

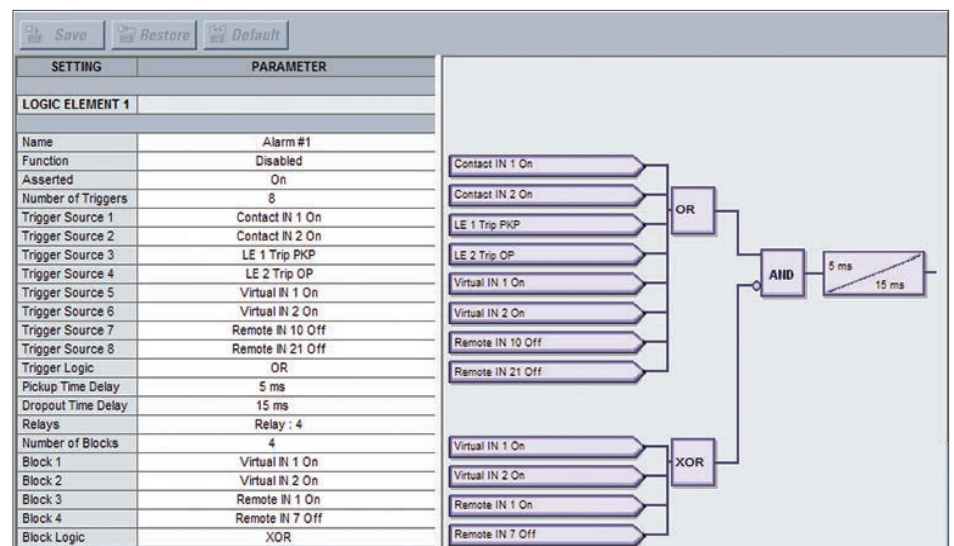

Sixteen logic elements available for applications such as manual control, interlocking and peer to peer tripping.

- Handles information exchange between devices as fast as 8 ms, depending on the architecture.
- Enables sequence coordination with upstream and downstream devices.
- If Breaker Open operation malfunctions, GOOSE messaging sends a signal to the upstream breaker to trip and clear the fault.

Logic Elements

The 350 relay has sixteen Logic Elements available for the user to build simple logic using the state of any programmed contact, virtual, or remote input, or the output operand of a protection or control element.

Use the logic element feature to assign up to eight triggering inputs in an “AND/OR/NOR/NAND/XOR/XNOR” gate for the logic element operation, and up to four blocking inputs in an “AND/OR/NOR/NAND/XOR/XNOR” gate for defining the block signal. Pickup and dropout timers are available for delaying the operation and reset.

Virtual Inputs

Virtual inputs allow communication devices the ability to write digital commands to the 350 relay. These commands can include open/close the breaker, changing setting groups, or blocking any of the protection elements.

Multiple Settings Groups

Two separate settings groups are stored in nonvolatile memory, with only one group active at a given time. Switching between the two setting groups is done by means of a setting, a communications command, or contact input activation. The two settings groups

SECURITY/CHANGE HISTORY REPORT
Generated at: September 15 2010 16:56:05

Device Summary

Device Name:	350
Device Type:	SR 350
Order Code:	350-EPOG0HSSNM2EDN
Firmware Version:	1.20
Serial Number:	BLOA10000019
Communication:	COM 3, 115200

Setting Changes History

Session#	Date of Change	Method of Change	# Of Changes	Password Entered	Changes by Whom IP /Mac	Event Type	Filename	Status	Firm. Version
1	09/15/2010 04:40:11 PM	USB	0	Yes	0:0:0:0	Setpoint File		Relay Not Ready	120
2	09/15/2010 04:41:36 PM	Ethernet	1	Yes	3:13:81:141	Setpoint Change	350_120.ar3 : C:	Relay Not Ready	120

Setting Changes Detail History

Session#	Date Of Change	Old Value	New Value	Data Item	Modbus Address
2	09/15/2010 04:41:36 PM	1	1	Config Revision Number	0X1266
3	09/15/2010 04:44:48 PM	1	1	Config Revision Number	0X1266
4	09/15/2010 04:46:20 PM	50	5	Ground CT Primary	0X10e

GE Multilin EnerVista VIEWPOINT maintenance

Trace any setting changes with security audit trail

allow users to quickly adapt settings to match new power system conditions, or to maintain alternate profiles such as settings used during maintenance operations.

Metering, Monitoring and Diagnostics

Event Recording

Events consist of a broad range of change of state occurrences, including pickups, trips, contact operations, alarms and self test status. The 350 relay stores up to 256 events, time tagged to the nearest millisecond. This provides the information required to determine sequence

of events, facilitating the diagnosis of relay operation. Event types are individually maskable in order to avoid generating undesired events, and include the metered values at the moment of the event.

Oscillography/ Transient Fault Recorder

The 350 captures current and voltage waveforms and digital channels at up to 32 samples per cycle (user-selectable). Multiple records can be stored in the relay at any given time with a maximum length of 192 cycles. Oscillography is triggered either by internal signals or an external contact.

Power System Troubleshooting

Analyze power system disturbances with transient fault recorder and event records

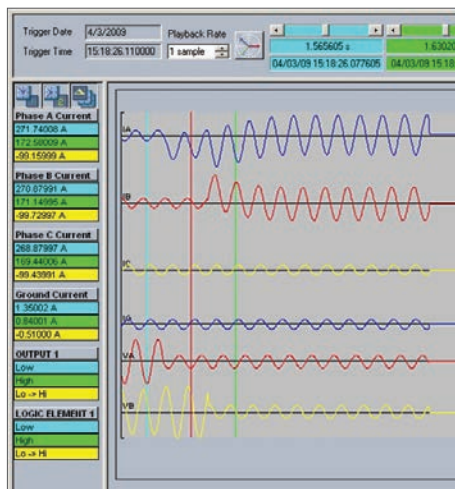

Event Records // Quick Connect: Quick Connect Device: Actual Values: A3 Records

Event	Select	Date	Time	Cause of Event
76	<input type="checkbox"/>	03/4/2009	15:02:55.561	Reset
75	<input checked="" type="checkbox"/>	03/4/2009	15:02:12.908	Breaker Status Open
74	<input type="checkbox"/>	03/4/2009	15:02:12.901	Contact Input 1 Off
73	<input type="checkbox"/>	03/4/2009	15:02:11.775	Phase C TOC Trip Operate
72	<input type="checkbox"/>	03/4/2009	15:02:11.775	Phase A TOC Trip Operate
71	<input type="checkbox"/>	03/4/2009	15:02:11.759	Output Relay 3
70	<input type="checkbox"/>	03/4/2009	15:02:11.759	Trip Coil
69	<input type="checkbox"/>	03/4/2009	15:02:11.759	Trip Coil Pickup
68	<input type="checkbox"/>	03/4/2009	15:02:11.758	Phase TOC Trip Operate
67	<input type="checkbox"/>	03/4/2009	15:02:11.758	Phase B TOC Trip Operate

All None Select Events: 75

Event Parameter	Value
Event Ia	0° Lag
Event Ib	120° Lag
Event Ic	240° Lag
Event Ig	0° Lag
Event Frequency	59.99 Hz
Therm Cap PH A	0.0%
Therm Cap PH B	0.0%
Therm Cap PH C	0.0%

Fault Report // New Site 1: SR350_USB: Actual Values: A3 Recor...

Save Restore Default

PARAMETER	VALUE
Fault Report Order Code	350-LP5GSHMVCVSEDN
Fault Report Feeder Name	Feeder Name
Fault Report Firmware Version	2.20
Fault Report Date	06/30/2016
Fault Report Time	07:35:17
Fault Report Fault Type	Phase IOCI Trip OP
Active Setpoint Group	Group 1
Fault Report Ia	40.0 A
Fault Report Ia Angle	358°
Fault Report Ib	40.0 A
Fault Report Ib Angle	117°
Fault Report Ic	39.3 A
Fault Report Ic Angle	237°
Fault Report Ig	0.0 A
Fault Report Ig Angle	0°
Fault Report In	0.0 A
Fault Report In Angle	0°
Fault Report Va	30 V
Fault Report Va Angle	0°
Fault Report Vb	30 V
Fault Report Vb Angle	120°
Fault Report Vc	30 V
Fault Report Vc Angle	240°
Fault Report Vab	52 V

Example of Redundant HSR and PRP Architecture

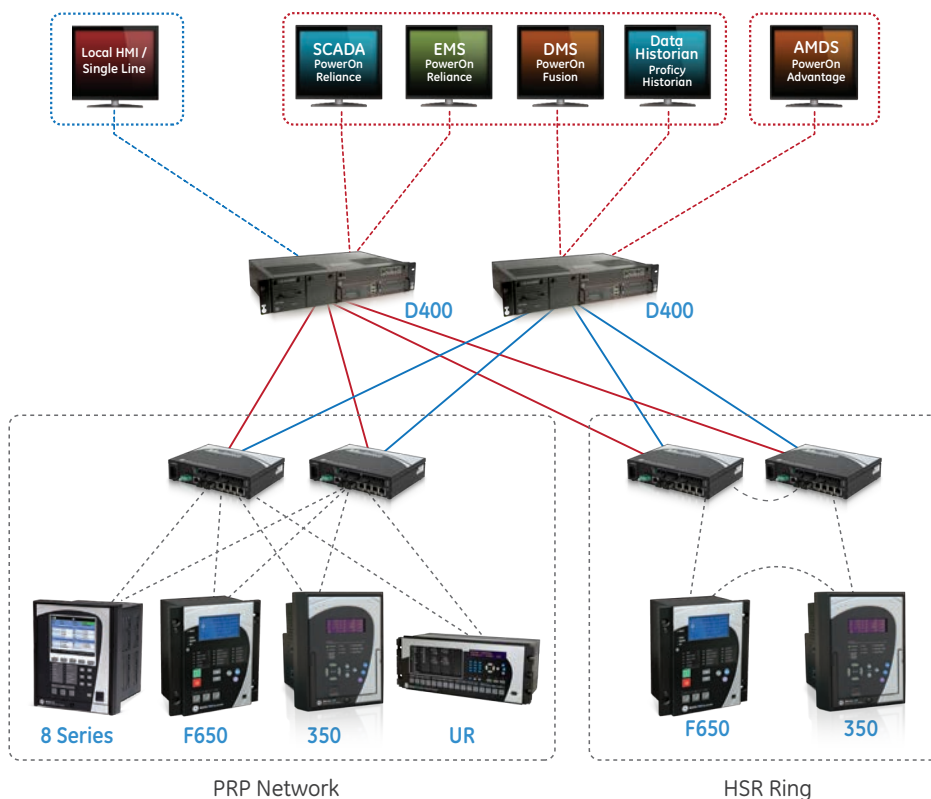

Redundancy protocols (PRP and HSR) can be used for various networking architectures including combined PRP/HSR topologies.

Test Mode

The Test Mode for 3 Series relays consists of testing front panel LEDs, Inputs and Outputs. It can be used to test the SCADA system as well.

Trip/Close Coil Monitoring

The 350 can be used to monitor the integrity of both the breaker trip and closing coils and circuits. The supervision inputs monitor both the auxiliary voltage levels, while the outputs monitor the continuity of the trip and/or closing circuits, by applying a small current through the circuits.

Metering

Metered values include:

- Current: Ia, Ib, Ic, In, Ig, Isg
- Phase-to-phase and phase-to-ground voltages for bus and line: Van, Vbn, Vcn, Vab, Vbc, Vca and Frequency
- Demand (different types), Active and Reactive power (3-Phase)

Advanced Device Health Diagnostics

The 350 performs comprehensive device health diagnostic tests during startup and continuously at runtime to test major functions and critical hardware. These diagnostic tests monitor for conditions that could impact system reliability. Device status is communicated via SCADA communications and the front panel display. This continuous monitoring and early detection of possible issues helps improve system availability by employing predictive maintenance.

Time Synchronization

The IEEE 1588 Precision Time Protocol (PTP) synchronizes the time between different nodes on an Ethernet network and is used when very precise time synchronization is required.

It is possible to synchronize distributed clocks with an accuracy of less than 1 microsecond via Ethernet networks. PTP enables clock redundancy and reduces wiring and testing. It can operate over a complete facility and has the ability to compensate for lead length.

IRIG-B is a standard time code format that allows time stamping of events to be synchronized among connected devices to within 1 millisecond. An IRIG-B input is provided in the 350 to allow time synchronization using a GPS clock over a wide area. The 350 IRIG-B supports both AM and DC time synchronization, with an auto detect feature that eliminates the need for configuration.

Temperature Monitoring

The 350 continually monitors ambient temperature around the relay and alarms when the device is exposed to extreme temperatures and undesirable conditions such as air-conditioning unit or station heater failures.

The EnerVista Viewpoint maintenance tool allows users to review and analyze the time period a 350 relay is exposed to certain temperature ranges.

Security

Password Control

The password system has been designed to facilitate a hierarchy for centralized management. With the implementation of the Password Security feature in the 350 relay, extra measures have been taken to ensure unauthorized changes are not made to the relay. When password security is enabled, changing of setpoints or issuing of commands requires passwords to be entered. Separate passwords are supported for remote and local operators, and separate access levels support changing of setpoints or sending commands.

Advanced Communications

The 350 incorporates the latest communication technologies, making it the easiest and the most flexible feeder protection relay for use and integration into new and existing infrastructures. The 350 relay provides the user with one front USB and one rear RS485 communication port. Also available with the 350 is a rear communication port with Ethernet Fiber and Copper. For configurations requiring PRP and HSR redundancy protocols, the 350 provides two rear Fiber ports. Through the use of these ports, continuous monitoring and control from a remote computer, SCADA system or PLC is possible.

The 350 provides optional Parallel Redundancy Protocol (PRP) and High Availability Seamless Ring (HSR) according to the IEC 62439-3 standard that defines two protocols to increase network availability by reducing failover time to zero. Both ports are capable of simultaneously supporting the following protocols: Modbus TCP/IP, IEC 61850, DNP3 or IEC 60870-5-104, IEEE 1588, SNTP and OPC-UA.

The basic concept of both protocols, PRP and HSR, is to send identical frames over different paths and discard one of the copies in reception, at best. If an error occurs or one of the paths goes down, the frame travelling through that path will not reach its destination, but its copy remains intact and will reach the desired destination. This technology ensures high reliability and availability of communication networks by providing redundancy and zero reconfiguration time in the event of a failure. Failsafe communications systems are crucial for industries and utilities with critical applications where no recovery time is tolerated.

The 350 supports popular industry-leading standard protocols enabling easy, direct integration into electrical SCADA and HMI systems. The protocols supported by the 350 include:

- IEC 61850
- IEC 60870-5-104
- IEC 61850 GOOSE
- PRP and HSR (IEC 62439-3)
- DNP 3.0
- OPC-UA
- Modbus RTU
- IEEE 1588 for time synchronization
- Modbus TCP/IP
- IEC 60870-5-103

The 350 relay provides Precision Time Protocol (PTP) based on IEEE 1588 for precise time synchronization throughout a network. OPC-UA based on IEC 62541 is another feature that the 350 relay offers.

These protocols make it easy to connect to a utility or industrial automation system, eliminating the need for external protocol converter devices.

EnerVista Software

The EnerVista suite is an industry leading set of software programs that simplifies every aspect of using the 350 relay. The EnerVista suite provides all the tools to monitor the status of the protected asset, maintain the relay, and integrate the information measured into DCS or SCADA monitoring systems. Convenient COMTRADE and sequence of event viewers are an integral part of the 350 set up software and are included to ensure proper protection and system operation.

Simplified Feeder Setup

The 350 Feeder Protection System includes a simplified setup process. This simplified feeder setup consists of minimal settings and can be accessed through the relay front panel or via the EnerVista Setup software. Once the information is entered, the simplified setup will generate a settings file, and provide documentation indicating which settings are enabled along with an explanation of the parameters entered.

Viewpoint Monitoring

Viewpoint Monitoring is a simple to use and full featured monitoring and data recording software package for small systems. Viewpoint monitoring provides a complete HMI package with the following functionality:

- Plug and play device monitoring
- System single line monitoring and control
- Annunciator alarm screens
- Trending reports
- Automatic event retrieval
- Automatic waveform retrieval

Viewpoint Maintenance

Viewpoint Maintenance provides tools that will increase the security of the 3 Series. Viewpoint Maintenance will create reports on the operating status of the relay, and simplify the steps to troubleshoot protected motors.

The tools available in Viewpoint Maintenance include:

- Settings Security Audit Trail
- Device Health Report
- Comprehensive Fault Diagnostics

EnerVista Integrator

EnerVista Integrator is a toolkit that allows seamless integration of Multilin devices into new or existing automation systems.

Included in the EnerVista Integrator is:

- OPC/DDE Server
- Multilin Devices
- Automatic Event Retrieval
- Automatic Waveform Retrieval

Display

A 4-line liquid crystal display (LCD) allows visibility under varied lighting conditions. When the keypad and display are not being used, the metering summary page is displayed to show critical metered values.

LEDs

The 350 relay has 12* LEDs, including 8 optional programmable LEDs that provide status indication for various conditions of the relay and the system. The LED indications are color coded to indicate the type of event.

* 10 non programmable LEDs for the non-drawout design

User Interface

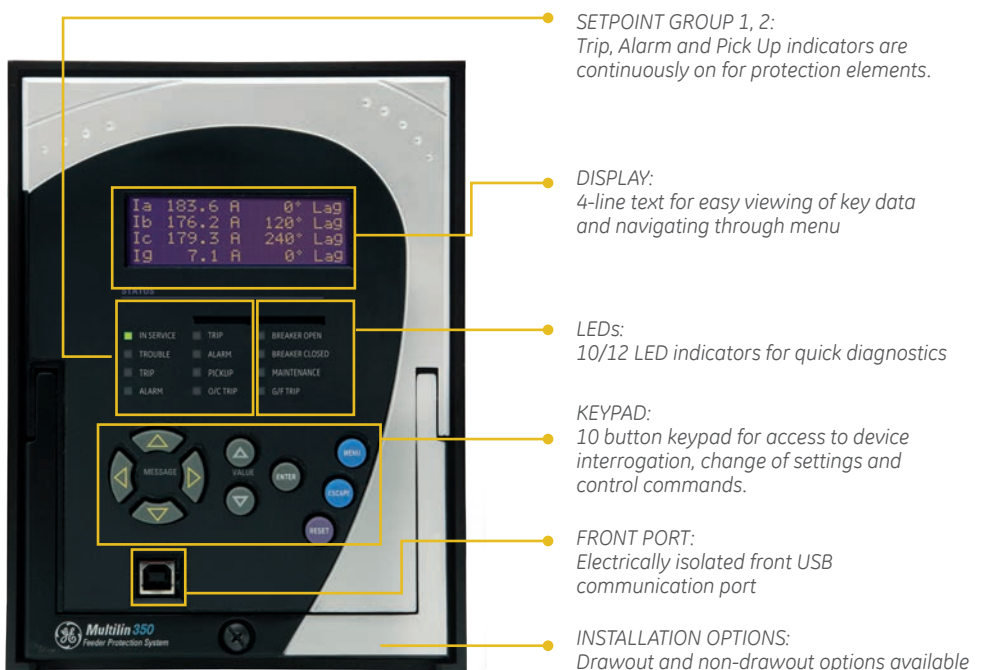

Feeder protection settings in one easy step

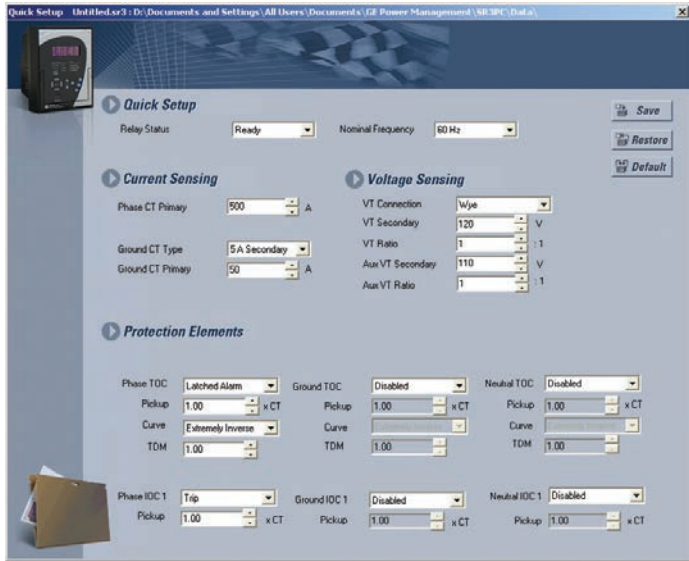

Fast and accurate configuration in one simple screen.

The screenshot shows a summary table for protection and control configuration. It includes columns for 'GROUPED ELEMENTS', 'OUTPUT RELAYS' (R3, R4, R5, R6), and 'CONTROL ELEMENTS'. The table lists various protection elements like Phase TOC, Ground TOC, Neutral TOC, etc., and their status across different relays.

GROUPED ELEMENTS	OUTPUT RELAYS				GROUP 1	OUTPUT RELAYS				GROUP 2
	R3	R4	R5	R6		R3	R4	R5	R6	
Phase TOC	<input checked="" type="checkbox"/>	<input checked="" type="checkbox"/>	<input checked="" type="checkbox"/>	<input checked="" type="checkbox"/>	Latched Alarm	<input type="checkbox"/>	<input type="checkbox"/>	<input type="checkbox"/>	<input type="checkbox"/>	Trip
Phase IOC1	<input checked="" type="checkbox"/>	<input checked="" type="checkbox"/>	<input checked="" type="checkbox"/>	<input checked="" type="checkbox"/>	Trip	<input type="checkbox"/>	<input type="checkbox"/>	<input type="checkbox"/>	<input type="checkbox"/>	Latched Alarm
Phase IOC2	<input type="checkbox"/>	<input type="checkbox"/>	<input type="checkbox"/>	<input type="checkbox"/>	Disabled	<input type="checkbox"/>	<input type="checkbox"/>	<input type="checkbox"/>	<input type="checkbox"/>	Disabled
Ground TOC	<input type="checkbox"/>	<input type="checkbox"/>	<input type="checkbox"/>	<input type="checkbox"/>	Disabled	<input type="checkbox"/>	<input type="checkbox"/>	<input checked="" type="checkbox"/>	<input type="checkbox"/>	Alarm
Ground IOC1	<input type="checkbox"/>	<input type="checkbox"/>	<input type="checkbox"/>	<input type="checkbox"/>	Disabled	<input type="checkbox"/>	<input type="checkbox"/>	<input type="checkbox"/>	<input type="checkbox"/>	Disabled
Ground IOC2	<input type="checkbox"/>	<input type="checkbox"/>	<input type="checkbox"/>	<input type="checkbox"/>	Disabled	<input type="checkbox"/>	<input type="checkbox"/>	<input type="checkbox"/>	<input type="checkbox"/>	Disabled
Ground Directional	<input type="checkbox"/>	<input type="checkbox"/>	<input type="checkbox"/>	<input type="checkbox"/>	Disabled	<input type="checkbox"/>	<input type="checkbox"/>	<input type="checkbox"/>	<input type="checkbox"/>	Disabled
Neutral TOC	<input type="checkbox"/>	<input type="checkbox"/>	<input type="checkbox"/>	<input type="checkbox"/>	Alarm	<input type="checkbox"/>	<input type="checkbox"/>	<input type="checkbox"/>	<input type="checkbox"/>	Disabled
Neutral IOC1	<input checked="" type="checkbox"/>	<input type="checkbox"/>	<input type="checkbox"/>	<input checked="" type="checkbox"/>	Latched Alarm	<input type="checkbox"/>	<input type="checkbox"/>	<input type="checkbox"/>	<input type="checkbox"/>	Disabled
Neutral IOC2	<input type="checkbox"/>	<input type="checkbox"/>	<input type="checkbox"/>	<input type="checkbox"/>	Disabled	<input type="checkbox"/>	<input type="checkbox"/>	<input type="checkbox"/>	<input type="checkbox"/>	Disabled
Neutral Directional	<input type="checkbox"/>	<input type="checkbox"/>	<input type="checkbox"/>	<input type="checkbox"/>	Disabled	<input type="checkbox"/>	<input type="checkbox"/>	<input type="checkbox"/>	<input type="checkbox"/>	Disabled
Negative Sequence IOC	<input type="checkbox"/>	<input type="checkbox"/>	<input type="checkbox"/>	<input type="checkbox"/>	Disabled	<input type="checkbox"/>	<input type="checkbox"/>	<input type="checkbox"/>	<input type="checkbox"/>	Disabled
Phase UV	<input checked="" type="checkbox"/>	<input type="checkbox"/>	<input type="checkbox"/>	<input checked="" type="checkbox"/>	Trip	<input type="checkbox"/>	<input type="checkbox"/>	<input type="checkbox"/>	<input type="checkbox"/>	Disabled
Phase OV	<input type="checkbox"/>	<input type="checkbox"/>	<input type="checkbox"/>	<input type="checkbox"/>	Disabled	<input type="checkbox"/>	<input type="checkbox"/>	<input type="checkbox"/>	<input type="checkbox"/>	Disabled
Neutral OV	<input type="checkbox"/>	<input type="checkbox"/>	<input type="checkbox"/>	<input type="checkbox"/>	Disabled	<input type="checkbox"/>	<input type="checkbox"/>	<input type="checkbox"/>	<input type="checkbox"/>	Disabled
Negative Sequence OV	<input type="checkbox"/>	<input type="checkbox"/>	<input type="checkbox"/>	<input type="checkbox"/>	Disabled	<input type="checkbox"/>	<input type="checkbox"/>	<input type="checkbox"/>	<input type="checkbox"/>	Disabled
Auxiliary UV	<input type="checkbox"/>	<input type="checkbox"/>	<input type="checkbox"/>	<input type="checkbox"/>	Disabled	<input type="checkbox"/>	<input type="checkbox"/>	<input type="checkbox"/>	<input type="checkbox"/>	Disabled
Auxiliary OV	<input type="checkbox"/>	<input type="checkbox"/>	<input type="checkbox"/>	<input type="checkbox"/>	Disabled	<input type="checkbox"/>	<input type="checkbox"/>	<input type="checkbox"/>	<input type="checkbox"/>	Disabled
Under-frequency 1	<input checked="" type="checkbox"/>	<input type="checkbox"/>	<input type="checkbox"/>	<input checked="" type="checkbox"/>	Trip	<input type="checkbox"/>	<input type="checkbox"/>	<input type="checkbox"/>	<input type="checkbox"/>	Disabled
Under-frequency 2	<input type="checkbox"/>	<input type="checkbox"/>	<input type="checkbox"/>	<input type="checkbox"/>	Disabled	<input type="checkbox"/>	<input type="checkbox"/>	<input type="checkbox"/>	<input type="checkbox"/>	Disabled
Over-frequency 1	<input type="checkbox"/>	<input type="checkbox"/>	<input type="checkbox"/>	<input type="checkbox"/>	Disabled	<input type="checkbox"/>	<input type="checkbox"/>	<input type="checkbox"/>	<input type="checkbox"/>	Disabled
Over-frequency 2	<input type="checkbox"/>	<input type="checkbox"/>	<input type="checkbox"/>	<input type="checkbox"/>	Disabled	<input type="checkbox"/>	<input type="checkbox"/>	<input type="checkbox"/>	<input type="checkbox"/>	Disabled
Cable Thermal Model	<input type="checkbox"/>	<input type="checkbox"/>	<input type="checkbox"/>	<input type="checkbox"/>	Disabled	<input type="checkbox"/>	<input type="checkbox"/>	<input type="checkbox"/>	<input type="checkbox"/>	Disabled
OUTPUT RELAYS										
CONTROL ELEMENTS	R3	R4	R5	R6	STATUS					
Logic Element 1	<input type="checkbox"/>	<input type="checkbox"/>	<input type="checkbox"/>	<input type="checkbox"/>	Disabled					
Logic Element 2	<input type="checkbox"/>	<input type="checkbox"/>	<input type="checkbox"/>	<input type="checkbox"/>	Disabled					
Unlabeled12.sr3										

3 Series setup software protection summary for viewing a summary of Protection & Control configuration.

Retrofit Existing Multilin MII Family Devices

Traditionally, retrofitting or upgrading an existing relay has been a challenging and time consuming task often requiring re-engineering, panel modifications and re-wiring. Similar features and form factor of some models of MII family devices allow users to replace their existing relays with 3 Series relays with enhanced protection and control features and advanced communications.

The SR3 Enervista Setup software allows users to create new setting files based on existing MIFII and MIVII setting files and can be uploaded to a 350 relay with a compatible model number. Retrofit is smooth and simplified with minor wiring or switchgear modifications.



The screenshot shows a 'Display Filter' section with 9 'Successfully Converted' items, 3 'Needs Verification' items, and 1 'Needs Manual configuration' item. Below is a table comparing 'SettingName', 'SettingValue', 'Original SettingName', and 'Original SettingValue'.

SettingName	SettingValue	Original SettingName	Original SettingValue
File			
Relay Information			
ProductName	350	ProductName	MIF
Version	220	Version	303
Notes			
Rest Of the settings are defaulted			
Setpoints			
S1 Relay Setup			
Communications			
RS485			
RS485 Comm Parity	None		
Rear 485 Protocol	Modbus		
Ethernet			
IP Settings			
Ethernet IP address	0		
Ethernet subnet mask	4294966272		
Ethernet gateway address	0		
Transient Recorder			
Transient Buffer Setup	1 x 192		
Trigger Mode	Overwrite		
Trace Memory Trigger Position	8 %		

Dimensions

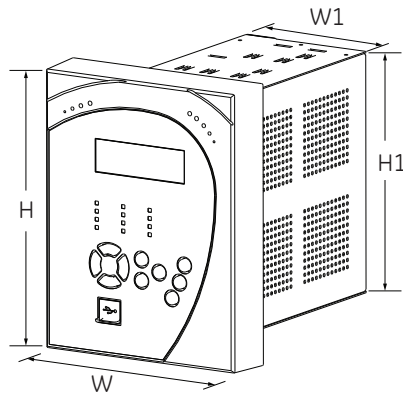
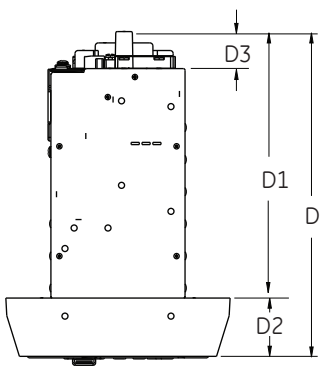

	DRAWOUT		NON-DRAWOUT	
	in	mm	in	mm
H	7.93	201.5	7.98	202.7
W	6.62	168.2	6.23	158.2
D	9.62	244.2	9.35	237.5
W1	3.96	100.6	3.96	100.6
D1	7.89	200.4	7.88	200.2
D2	1.73	43.8	1.47	37.3
D3	1.087	27.6	0.755	19.17
H1	6.82	173.2	6.82	173.2

Mounting

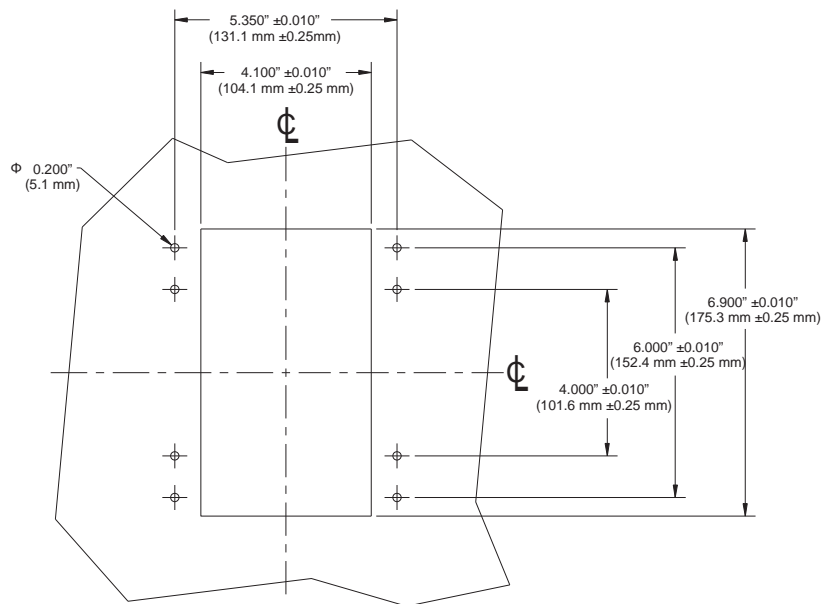

3 Series Depth Reducing Collar

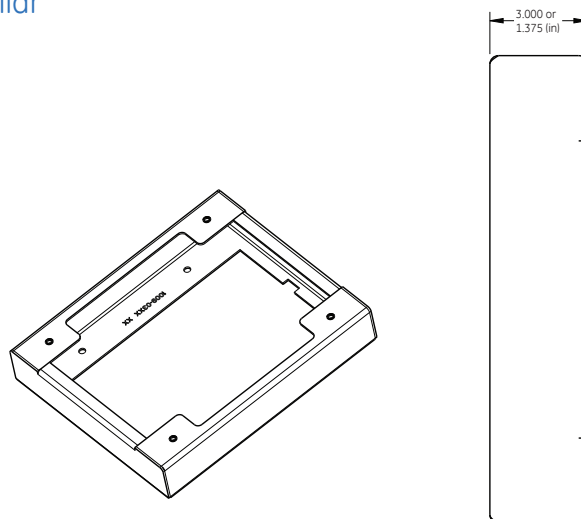

Typical Wiring Diagram - Drawout

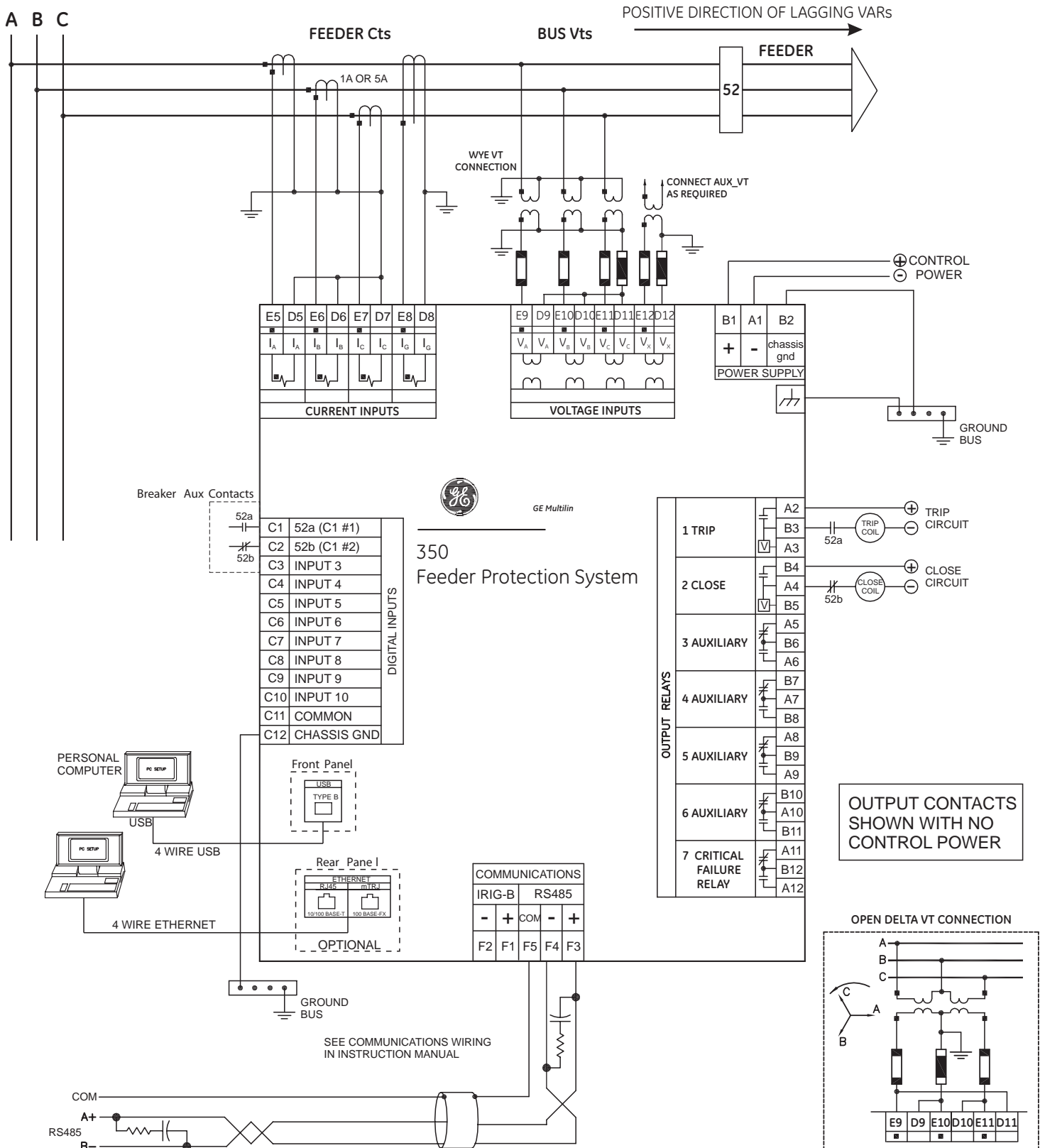

Current Inputs does not exist in "V" option. Please refer to the manual for non-drawout wiring.

Technical Specifications

PASSWORD SECURITY	
Master Reset Password	8 to 10 alpha-numeric characters
Settings Password	3 to 10 alpha-numeric characters for local and remote access
Control Password	3 to 10 alpha-numeric characters for local and remote access

PHASE/NEUTRAL/GROUND/NEGATIVE SEQUENCE TIME OVERCURRENT (51P/51N/51G/51 2)	
Pickup Level:	0.05 to 20.00 x CT in steps of 0.01 x CT
Dropout Level:	97 to 99% of Pickup @ I > 1 x CT Pickup - 0.02 x CT @ I < 1 x CT
Curve Shape:	ANSI Extremely/Very/Moderately/Normally Inverse Definite Time (0.1 s base curve) IEC Curve A/B/C/Short IAC Extreme/Very/Inverse/Short User Curve, FlexCurve™ A/B (programmable curves)
Curve Multiplier:	0.05 to 50.00 in steps of 0.01
Reset Time:	Instantaneous, Linear
Time Delay Accuracy:	±3% of expected inverse time or 1.5 cycle, whichever is greater, from pickup to operate
Level Accuracy:	per CT input

SENSITIVE GROUND TIME OVERCURRENT (51SG)	
Pickup Level:	0.005 to 3.000 x CT in steps of 0.001 x CT
Dropout Level:	97 to 99% of Pickup @ I > 0.1 x CT Pickup - 0.002 x CT @ I < 0.1 x CT
Curve Shape:	ANSI Extremely/Very/Moderately/Normally Inverse Definite Time (0.1 s base curve) IEC Curve A/B/C/Short Inverse IAC Extreme/Very/Inverse/Short Inverse User Curve, FlexCurve™ A/B
Curve Multiplier:	0.05 to 50.00 in steps of 0.01
Reset Time:	Instantaneous, Linear
Time Delay Accuracy:	±3% of expected inverse time or 1 cycle, whichever is greater, from pickup to operate
Level Accuracy:	per CT input

PHASE/NEUTRAL/GROUND/NEGATIVE SEQUENCE INSTANTANEOUS OVERCURRENT (50P/50N/50G/50 2)	
Pickup Level:	0.05 to 20 x CT in steps of 0.01 x CT
Dropout Level:	97 to 99% of Pickup @ I > 1 x CT Pickup - 0.02 x CT @ I < 1 x CT
Time delay:	0.00 to 300.00 sec in steps of 0.01
Operate Time:	<30 ms @ 60Hz (I > 2.0 x PKP, No time delay) <35 ms @ 50Hz (I > 2.0 x PKP, No time delay)
Time Delay Accuracy:	1% or 1 cycle, whichever is greater (Time Delay selected)
Level Accuracy:	per CT input

SENSITIVE GROUND INSTANTANEOUS OVERCURRENT (50SG)	
Pickup Level:	0.005 to 3 x CT in steps of 0.001 x CT
Dropout Level:	97 to 99% of Pickup @ I > 0.1 x CT Pickup - 0.002 x CT @ I < 0.1 x CT
Time delay:	0.00 to 300.00 sec in steps of 0.01
Operate Time:	<30 ms @ 60Hz (I > 2.0 x PKP, No time delay) <35 ms @ 50Hz (I > 2.0 x PKP, No time delay)
Time Delay Accuracy:	1% or 1 cycle, whichever is greater (Time Delay selected)
Level Accuracy:	per CT input

PHASE DIRECTIONAL (67P)	
Directionality:	Co-existing forward and reverse
Operating:	Phase Current (Ia, Ib, Ic)
Polarizing Voltage:	Quadrature Voltage (ABC phase sequence: Vbc, Vca, Vab) (CBA phase sequence: Vcb, Vac, Vba)
Polarizing Voltage Threshold	0.05 to 1.25 x VT in steps of 0.01
MTA	From 0° to 359° in steps of 1°
Angle Accuracy:	±4°
Operation Delay:	20 to 30 ms

METERING SPECIFICATIONS			
Parameter	Accuracy	Resolution	Range
3-Phase Real Power (kW)	±1% of full scale	0.1 MW	±100000.0 kW
3-Phase Reactive Power (kvar)	±1% of full scale	0.1 Mvar	±100000.0 kvar
3-Phase Apparent Power (kVA)	±1% of full scale	0.1 MVA	100000.0 kVA
3-Phase Positive Watthour (MWh)	±1% of full scale	±0.001 MWh	50000.0 MWh
3-Phase Negative Watthour (MWh)	±1% of full scale	±0.001 MWh	50000.0 MWh
3-Phase Positive Varhour (Mvarh)	±1% of full scale	±0.001 Mvarh	50000.0 Mvarh
3-Phase Negative Varhour (Mvarh)	±1% of full scale	±0.001 Mvarh	50000.0 Mvarh
Power Factor	±0.05	0.01	-0.99 to 1.00
Frequency	±0.05 Hz	0.01 Hz	40.00 to 70.00 Hz

Note: Full scale for CT Input is 3 x CT. Negative values (-) represent lead and positive values (+) represent lag.

Current Parameters: Phase A, Phase B, Phase C, Neutral, Ground, Sensitive Ground, Positive Sequence, Negative Sequence and Zero Sequence

GROUND DIRECTIONAL (67G)	
Directionality:	Co-existing forward and reverse
Operating:	Ground Current (I _g)
Polarizing Voltage:	- V _g calculated using phase voltages (VTs must be connected in "Wye") - 3V _g measured from Vaux input (3V _g provided by an external open delta connection).
MTA:	From 0° to 359° in steps of 1°
Angle Accuracy:	±4°
Operation Delay:	20 to 30 ms

NEUTRAL DIRECTIONAL (67N)	
Directionality:	Co-existing forward and reverse
Polarizing:	Voltage, Current, Dual
Polarizing Voltage:	- V _n calculated using phase voltages (VTs must be connected in "Wye") - 3V _n measured by Vaux input (3V _n provided by an external open delta connection).
Polarizing Current:	I _g
MTA:	From 0° to 359° in steps of 1°
Angle Accuracy:	±4°
Operation Delay:	20 to 30 ms

THERMAL OVERLOAD (49)	
Current:	RMS current - max (Ia, Ib, Ic)
Pickup Accuracy:	per current inputs
Timing Accuracy:	See graph below

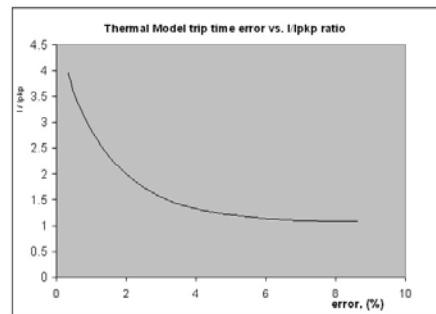

The graph shows the trip time error with respect to the ratio of cable load and thermal model pickup setting. With a smaller I/pkp ratio, the time error tends to be higher, as accumulated through the logarithmic formula, the measurement error, and the time of measurement. For higher I/pkp ratios, the time to trip is substantially more accurate. Each point on the graph represents a trip time error, with the I/pkp ratio kept constant during the test.

PHASE/AUXILIARY/POSITIVE SEQUENCE UNDERVOLTAGE (27P, 27X, 27 1)	
Minimum Voltage:	Programmable from 0.00 to 1.25 x VT in steps of 0.01
Pickup Level:	0.00 to 1.25 x VT in steps of 0.01
Dropout Level:	101 to 104% of pickup
Curve:	Definite Time, Inverse Time
Time Delay:	0.1 to 600.0 s in steps of 0.1
Operate Time:	Time delay ±30 ms @ 60Hz (V < 0.85 x PKP) Time delay ±40 ms @ 50Hz (V < 0.85 x PKP)
Time Delay Accuracy:	±3% of expected inverse time or 1 cycle, whichever is greater
Level Accuracy:	Per voltage input

PHASE/AUXILIARY/NEUTRAL/NEGATIVE SEQ OVERVOLTAGE (59P/59X/59N/59 2)	
Pickup Level:	0.00 to 1.25 x VT in steps of 0.01
Dropout Level:	96 to 99% of pickup
Time Delay:	0.1 to 600.0 s in steps of 0.1
Operate Time:	Time delay ±35 ms @ 60Hz (V > 1.1 x PKP) Time delay ±40 ms @ 50Hz (V > 1.1 x PKP)
Time Delay Accuracy:	±3% of expected inverse time or 1 cycle,
Level Accuracy:	Per voltage input

BROKEN CONDUCTOR (46BC)	
Minimum operating positive current	0.05 to 1.00 x CT in steps of 0.01 x CT
Maximum operating positive current:	0.05 to 5.00 x CT in steps of 0.01 x CT
Pickup level	20.0% to 100.0% in steps of 0.1%
Dropout level:	97% to 98% of the pickup level
Pickup time delay	0.000 to 65.535 s in steps of 0.001 s
Timer accuracy	± 3% of delay setting or ± ¼ cycle (whichever is greater) from pickup to operate
Operate time	<30 ms at 60 Hz

WATTMETRIC GROUND FAULT (32N)	
Measured power	zero sequence
Number of elements:	1
Characteristic angle:	0° to 359° in steps of 1°
Pickup threshold:	0.001 to 1.200 pu in steps of 0.001 pu
Pickup level accuracy:	± 2% or ± 0.03 pu, whichever is greater
Hysteresis:	3% or 0.001 pu, whichever is greater
Pickup delay	Definite Time (0.00 to 600.0 s in steps of 0.1 s), Inverse Time, or Flexcurve 0.01 to 2.00 in steps of 0.01
Inverse time multiplier:	
Curve timing accuracy:	± 3.5% of operate time or ± ¼ cycle (whichever is greater) from pickup to operate
Operate time:	<30 ms at 60 Hz

DIRECTIONAL POWER (32)	
Measured power:	3-phase
Characteristic angle:	0° to 359° in steps of 1°
Power pickup range:	-1.200 to 1.200 x Rated Power in steps of 0.001
Pickup level accuracy:	2.5% or 0.01 pu, whichever is greater
Hysteresis:	2% or 0.001 x Rated Power, whichever is greater
Pickup time delay:	0.00 to 600.0 s in steps of 0.1 s
Operate time:	< 55 ms at 1.1 x pickup at 60 Hz < 65 ms at 1.1 x pickup at 50 Hz
Timer accuracy:	± 3% of delay setting or ± ¼ cycle (whichever is greater) from pickup to operate

UNDERFREQUENCY (81U)	
Minimum Voltage:	0.00 to 1.25 x VT in steps of 0.01
Pickup Level:	40.00 to 70.00 Hz in steps of 0.01
Dropout Level:	Pickup +0.05 Hz
Time Delay:	0.1 to 600.0 s in steps of 0.1
Time Delay Accuracy:	0 to 6 cycles (Time Delay selected)
Operate Time:	Typically 10 cycles @ 0.1Hz/s change
Level Accuracy:	±0.03 Hz

OVERFREQUENCY (81O)	
Minimum Voltage	0.3 x VT
Pickup Voltage:	40.00 to 70.00 Hz in steps of 0.01
Dropout Level:	Pickup -0.05 Hz
Time Delay:	0.1 to 600.0 s in steps of 0.1
Time Delay Accuracy:	0 to 6 cycles (Time Delay selected)
Operate Time:	Typically 10 cycles @ 0.1Hz/s change
Level Accuracy:	±0.03 Hz

FUSE FAIL (VTFE)	
Time Delay:	1 s
Timing Accuracy:	±0.5 s
Elements:	Trip or Alarm

TRANSIENT RECORDER	
Buffer size:	3 s
No. of buffers:	1, 3, 6
No. of channels:	14
Sampling rate:	4, 8, 16, or 32 samples per cycle
Triggers:	Manual Command Contact Input Virtual Input Logic Element Element Pickup/Trip/Dropout/Alarm
Data:	AC input channels Contact input state Contact output state Virtual input state Logic element state
Data storage:	RAM - battery backed-up

FAULT RECORDER	
Number of records	1
Content:	Date and Time, first cause of fault, phases, Currents: Ia, Ib, Ic, I _g /I _{sg} , In - magnitudes and angles/Voltages: Van, Vbn, Vcn, Vab, Vbc, Vca, Vaux - magnitudes and angles System frequency

Technical Specifications

EVENT RECORDER	
Number of events:	256
Header:	relay name, order code, firmware revision
Content:	event number, date of event, cause of event, per-phase current, ground current, sensitive ground current, neutral current, per-phase voltage (VTs connected in "Wye"), or phase-phase voltages (VTs connected in "Delta"), system frequency, power, power factor, thermal capacity
Data Storage:	Retained for 3 days

CLOCK	
Setup:	Date and time Daylight Saving Time
IRIG-B:	Auto-detect (DC shift or Amplitude Modulated) Amplitude modulated: 1 to 10 V pk-pk DC shift: 1 to 10 V DC Input impedance: 40kOhm ± 10% Accuracy with IRIG-B: ± 1 ms Accuracy without IRIG-B: ± 1 min / month

LOGIC ELEMENTS	
Number of logic elements:	16
Trigger source inputs per element:	2 to 8
Block inputs per element:	2 to 4
Supported operations:	AND, OR, NOR, NAND, XOR, XNOR, Pickup / Dropout timers
Pickup timer:	0 to 60000 ms in steps of 1 ms
Dropout timer:	0 to 60000 ms in steps of 1 ms

BREAKER CONTROL	
Operation:	Asserted Contact Input, Logic Element, Virtual Input, Manual Command
Function:	Opens / closes the feeder breaker

SYNCHROCHECK (25)	
Dead/Live levels for Line and Bus:	0 to 1.25 × VT in steps of 0.01
Maximum voltage difference:	0.02 to 1.25 × VT in steps of 0.01
Maximum angle difference:	2° to 80° in steps of 1°
Maximum frequency slip:	0.01 to 5.00 Hz in steps of 0.01 Hz
Breaker Closing time:	0.01 to 1.00 s in steps of 0.01 s
Dead Source function:	None (DL-DB) Dead Line-Dead Bus (LL-DB) Live Line-Dead Bus (DL-LB) Dead Line-Live Bus (AL-DB) Any Line-Dead Bus (DL-AB) Dead Line-Any Bus (OL-OD) One Live-Other Dead (NBL) Not Both Live

AUTORECLOSE (79)	
Reclose attempts:	Up to 4 shots
Time Delay:	0 to 3 cycles (AR Dead Time selected)
Accuracy:	
Elements:	Inputs, Outputs, Breaker Status (52 status)

SYNCHROCHECK SUPERVISION	
Operation:	Automatically
Function:	Close breaker supervision

SECOND HARMONIC INHIBIT	
Operating Parameter:	Current 2nd harmonic per phase or average
Pickup Level:	0.1% to 40.0% in steps of 0.1
Minimum Current:	0.03 to 3.00 × CT in steps of 0.01 × CT
Time Delay:	0.00 to 600.00 s in steps of 0.01 s
Time Delay Accuracy:	±3% of expected time or 2 cycle, whichever is greater
Level Accuracy:	±2% or ±10mA (whichever is greater)

BREAKER FAILURE (50BF)	
Pickup Level:	0.05 to 20.00 × CT in steps of 0.01 × CT
Timer 1 Delay:	0.03 to 1.00 s in steps of 0.01 s
Timer 2 Delay:	0.00 to 1.00 s in steps of 0.01 s
Dropout Level:	97 to 98% of pickup
Time Delay:	0 to 1 cycle (Timer 1, Timer 2)
Accuracy:	
Level Accuracy:	per CT input
Reset Time:	<14 ms typical at 2 × pickup at 60 Hz <16 ms typical at 2 × pickup at 50 Hz

BREAKER TRIP COUNTER	
Trip Counter Limit (Pickup):	1 to 10000 in steps of 1

CT FAILURE	
Inputs:	Neutral Current IN, Neutral Current VN (from three-phase VTs) Ground Current Ig
Time Delay:	0.00 to 60.00 s in steps of 0.01 s
3I0 level accuracy:	per CT inputs
3V0 level accuracy:	per VT inputs
GND current level accuracy:	see the specifications for phase and ground current inputs
Operate Time:	< 30 ms @ 60 Hz (3I0 > 1.1×PKP, No time delay) < 35 ms @ 50 Hz (3I0 > 1.1×PKP, No time delay)

COLD LOAD PICKUP BLOCKING	
Operation:	Automatically (current level), or by command (asserted input)
Function:	Block IOC functions, raise TOC pickup, for selected period of time
Time Delay:	0 to 1 cycle (block Time)
Accuracy:	±50 ms (outage time ≤ 5 min) ±1 s (outage time > 5 min)

AMBIENT TEMPERATURE	
High Temperature Pickup:	20°C to 80°C in steps of 1°C
Low Temperature Pickup:	-40°C to 20°C in steps of 1°C
Time Delay:	1 to 60 min in steps of 1 min
Temperature Dropout:	Configurable 90 to 98% of pickup
Temperature Accuracy:	±10°C
Timing Accuracy:	±1 second

BREAKER HEALTH	
Timer Accuracy:	± 3% of delay setting or ± 1 cycle (whichever is greater) from pickup to operate

DEMAND	
Measured Values:	Phase A/B/C present and maximum current, three-phase present and maximum real/reactive/apparent power
Measurement Type:	Thermal Exponential, 90% response time (programmed): 5, 10, 15, 20, 30 minutes Block Interval / Rolling Demand, time interval (programmed): 5, 10, 15, 20, 30 minutes
Current Pickup Level:	10 to 10000 in steps of 1 A
Real Power Pickup Level:	0.1 to 300000.0 in steps of 0.1 kW
Reactive Power Pickup Level:	0.1 to 300000.0 in steps of 0.1 kVar
Apparent Power Pickup Level:	0.1 to 300000.0 in steps of 0.1 kVA
Dropout Level:	96-98% of Pickup level
Level Accuracy:	± 2% (current demand only)

CONTACT INPUTS	
Inputs:	10
Selectable thresholds:	17, 33, 84, 166 VDC ±10%
Recognition time:	1/2 cycle
Debounce time:	1 to 64 ms, selectable, in steps of 1 ms
Maximum input voltage & continuous current draw:	300 VDC, 2 mA, connected to Class 2 source
Type:	opto-isolated inputs
External switch:	wet contact

PHASE & GROUND CURRENT INPUTS	
CT Primary:	1 to 6000 A
Range:	0.02 to 20 × CT
Input type:	1 A or 5 A (must be specified with order)
Nominal frequency:	50/60 Hz
Burden:	<0.1 VA at rated load
Accuracy:	±1% of reading at 1 × CT ±3% of reading from 0.2 to 20 × CT +/- 10 mA or ±20% of reading from 0.02 to 0.19 × CT, whichever is greater
CT withstand:	1 second at 100 A (1 A option) 1 second at 400 A (5 A or universal CT option) 2 seconds at 40 × rated current continuous at 3 × rated current

SENSITIVE GROUND CURRENT INPUT	
CT Primary:	1 to 600 A
Range:	0.002 to 3 × CT
Input type:	1 A or 5 A (must be specified with order)
Nominal frequency:	50/60 Hz
Burden:	<0.1 VA at rated load
Accuracy:	±1% of reading at 0.1 × CT ±3% of reading from 0.02 to 3 × CT +/- 10 mA or ±20% of reading from 0.02 to 0.19 × CT, whichever is greater
CT withstand:	1 second at 100 A (1 A option) 1 second at 400 A (5 A or universal CT option) 2 seconds at 40 × rated current continuous at 3 × rated current

PHASE/AUX VOLTAGE INPUTS	
Source VT:	0.15 to 550 kV / 50 to 220 V
VT secondary:	50 to 240 V
VT ratio:	1.0 to 5000 in steps of 0.1
Nominal frequency:	50/60 Hz
Relay burden:	<0.25 VA at 120 V
Accuracy:	±1.0% of reading
Voltage withstand:	260 VAC continuous

FORM-A RELAYS	
Configuration:	2 (two) electromechanical
Contact material:	silver-alloy
Operate time:	<8 ms
Continuous current:	10 A
Make and carry for 0.2s:	30 A per ANSI C37.90
Break (DC inductive, L/R=40 ms):	24 V / 1 A 48 V / 0.5 A 125 V / 0.3 A 250 V / 0.2 A
Break (DC resistive):	24 V / 10 A 48 V / 6 A 125 V / 0.5 A 250 V / 0.3 A
Break (AC inductive):	720 VA @ 250 VAC Pilot duty A300
Break (AC resistive):	277 VAC / 10 A

FORM-A VOLTAGE MONITOR	
Applicable voltage:	20 to 250 VDC
Trickle current:	1 to 2.5 mA

FORM-C RELAYS	
Configuration:	5 (five) electromechanical
Contact material:	silver-alloy
Operate time:	<8 ms
Continuous current:	10 A
Make and carry for 0.2s:	30 A per ANSI C37.90
Break (DC inductive, L/R=40 ms):	24 V / 1 A 48 V / 0.5 A 125 V / 0.3 A 250 V / 0.2 A
Break (DC resistive):	24 V / 10 A 48 V / 6 A 125 V / 0.5 A 250 V / 0.3 A
Break (AC inductive):	720 VA @ 250 VAC Pilot duty A300
Break (AC resistive):	277 VAC / 10 A

TRIP / CLOSE SEAL-IN	
Relay 1 trip seal-in:	0.00 to 9.99 s in steps of 0.01
Relay 2 close seal-in:	0.00 to 9.99 s in steps of 0.01

HIGH RANGE POWER SUPPLY	
Nominal:	120 to 240 VAC 125 to 250 VDC
Range:	60 to 300 VAC (50 and 60 Hz) 84 to 250 VDC
Ride-through time:	35 ms

LOW RANGE POWER SUPPLY	
Nominal:	24 to 48 VDC
Range:	20 to 60 VDC

ALL RANGES	
Voltage withstand:	2 × highest nominal voltage for 10 ms
Power consumption:	15 W nominal, 20 W maximum 20 VA nominal, 28 VA maximum
Fuse rating:	5A fuse; time lag, slow blow, 350V 4.5 O.D. X 14.5mm

SERIAL	
RS485 port:	Opto-coupled
Baud rates:	up to 115 kbps
Response time:	1 ms typical
Parity:	None, Odd, Even
Maximum Distance:	1200 m (4000 feet)
Isolation:	2 kV
Protocol:	Modbus RTU, DNP 3.0, IEC 60870-5-103

ETHERNET (COPPER)	
Modes:	10/100 MB (auto-detect)
Connector:	RJ-45
Protocol:	Modbus TCP/IP, DNP 3.0, IEC 60870-5-104, IEC 61850 GOOSE, IEC 61850, OPC-UA

Technical Specifications

ETHERNET (FIBER)	
Fiber type:	100 MB Multi-mode
Wavelength:	1300 nm
Connector:	MTRJ
Transmit power:	-20 dBm
Receiver sensitivity:	-31 dBm
Power budget:	9 dB
Maximum input power:	-11.8 dBm
Typical distance:	2 km (1.25 miles)
Duplex:	half/full
Protocol:	Modbus TCP, DNP3.0, IEC 60870-5-104, IEC 61850 GOOSE, IEC 61850, OPC-UA, PRP, HSR
Maximum number of TCP/IP sessions:	3

USB	
Standard specification:	Compliant with USB 2.0
Data transfer rate:	115 kbps

OPC-UA (OLE FOR PROCESS CONTROL - UNIFIED ARCHITECTURE)	
DA Server:	Transmission of real-time data to Clients
A&E Server:	Transmission of Event information to Clients. Acknowledge and confirmation permitted from Client side

CERTIFICATION		
	Applicable council directive	According to
CE compliance	Low voltage directive EMC Directive	2014/35/EU 2014/30/EU UL 508
North America	cULus	UL 1053 C22.2 No 14
EAC	Machines and Equipment	TR CU 010/2011
Lloyd's Register	Rules and Regulations for the Classifications of Ships	Marine Applications: ENV2, ENV3
ISO	Manufactured under a registered quality program	ISO9001

EAC	
The EAC Technical Regulations (TR) for Machines and Equipment apply to the Customs Union (CU) of the Russian Federation, Belarus and Kazakhstan	
Country of origin	Spain or Canada; see label on the unit
Date of manufacture	See label on the side of the unit
Declaration of Conformity and/or Certificate of Conformity	Available upon request

TEST	REFERENCE STADARD	TEST LEVEL
Dielectric voltage withstand		
high vltage power supply*	60255-27	2200 VAC for one second
low vltage power supply*	60255-27	550 VAC for one second
Impulse voltage withstand	EN60255-27	5kV
Damped Oscillatory Discharge	IEC 60255-26/ IEC61000-4-18	2.5kV CM, 1 kV DM
Electrostatic Discharge	IEC 60255-26 / IEC 61000-4-2	15 kV / 8 kV
RF immunity	IEC 60255-26 / IEC 61000-4-3	80 MHz- 1 GHz, 1.4 Ghz-2.7Ghz, 10 V/m
Fast Transient Disturbance	IEC 60255-26 / IEC 61000-4-4	2 or 4 kV
Surge Immunity	IEC 60255-26 / IEC 61000-4-5	0.5, 1 & 2 kV
Conducted RF Immunity	IEC 60255-26 / IEC 61000-4-6	150 kHz-80 MHz, 26-68 MHz, 10V/m
Voltage interruption & Ripple DC	IEC 60255-26 / IEC 61000-4-11	15% ripple, 200ms interrupts
Radiated & Conducted Emissions	CISPR11 / CISPR22/ IEC 60255-26: Section 7.1.2 & 7.1.3	Class A
Sinusoidal Vibration	IEC 60255-21-1	Class 1
Shock & Bump	IEC 60255-21-2	Class 1
Seismic	IEC 60255-21-3	Class 2
Power magnetic Immunity	IEC 60255-26 / IEC 61000-4-8	1000 A/m, 100 A/m, 30A/m 300 A/m
Voltage Dip & interruption	IEC 60255-26 / IEC 61000-4-11	0, 40, 70, 80% dips, 250/300 cycle interrupts Level 4
Power frequency	IEC 60255-26 / IEC 61000-4-16	
Voltage Ripple	IEC 60255-26 / IEC 61000-4-17	15% ripple
Ingress Protection	IEC 60529	IP40 front, IP10 Back
Environmental (Cold)	IEC 60068-2-1	-40°C 16 hrs
Environmental (Dry heat)	IEC 60068-2-2	85°C 16hrs
Relative Humidity Cyclic	IEC 60068-2-30	6 day variant 2
EFT	IEEE / ANSI C37.90.1	4KV, 2.5Khz
Damped Oscillatory RF Immunity	IEEE / ANSI C37.90.1	2.5KV, 1Mhz
	IEEE / ANSI C37.90.2	35V/m (max field), (80 MHz-1 GHz with 1 KHz sine and 80% AM modulation)
ESD	IEEE / ANSI C37.90.3	8KV CD/ 15KV AD
Safety	UL 508 UL C22.2-14 UL 1053	e83849 NKCR e83849 NKCR7 e83849 NKCR

* Test level is based on basic insulation principle (Power supply I/P terminals tested to Chassis ground).

DIMENSIONS	
Size:	Refer to Dimensions section

WEIGHT	
NON-DRAWOUT UNIT	
Weight (net):	2.9 kg (6.4 lbs)
Weight (gross):	4.0 kg (8.6 lbs)
DRAWOUT UNIT	
Weight (net):	3.9 kg (8.6 lbs)
Weight (gross):	5.0 kg (11.0 lbs)

OPERATING ENVIRONMENT	
Ambient operating temperature:	-40°C to +60°C [-40°F to +140°F]
Ambient storage / shipping temperature:	-40°C to +85°C [-40°F to +185°F]
Humidity:	Operating up to 95% (non condensing) @ 55C (As per IEC 60068-2-30 Variant 2, 6days)
Altitude:	2000m (max)
Pollution degree:	II
Overvoltage category:	III
Ingress Protection:	IP42 Front , IP10 back (IP20 cover is available for drawout version)
Noise:	0 dB

Ordering

	350	-	*	*	*	*	*	*	*	*	*	*	*	*	*	*	Description
Interface	350																350 Feeder Protection System
Language ^a			E														English without programmable LEDs
			L														English with programmable LEDs
Phase Currents ^b				PX													No CT
				P0													1 A and 5 A configurable phase current inputs
				P1													1 A 3-phase current inputs
				P5													5 A 3-phase current inputs
Ground Currents ^c				GX													No CT
				G0													1 A and 5 A configurable ground current inputs
				G1													1 A ground current input
				G5													5 A ground current input
				S0													1 A and 5A configurable sensitive ground current inputs
				S1													1 A sensitive ground current input
				S5													5 A sensitive ground current input
Power Supply					L												24 to 48 V DC
					H												110 to 250 V DC/110 to 230 V AC
Input/Output						E											10 Inputs, 7 Outputs (2 Form A, 5 Form C)
Current Protection ^d								N									None (voltage and frequency relay, requires a PX/GX configuration)
								E									Extended configuration: 49, 50P(2), 50G/SG(2), 50N(2), 51P(1), 51G/SG(1), 51N(1)
								M									Advanced configuration: Extended + 51_2 or 46(1), 50_2 (1) or 46(1), I1/I2(46BC)
Control									N								CLP, Lockout (86)
									C								CLP, 50BF, Lockout (86), Autoreclose (79)
Other Options										N							No selection
										V							27P(4), 27X(1), 27P_1(1), 59P(4), 59N(4), 59X(1), 59_2(2), 81O(4), 81U(4), 25(1), VTFF(1), Voltage Metering (requires a PX/GX configuration)
										D							Neutral and Ground Directional Overcurrent Protection: 67N(1), 67G/SG(1), 60CTS
										M							Voltage, Power and Energy Metering, 60CTS
										R							Phase, Neutral and Ground Directional Overcurrent Protection: 67P(1), 67N(1), 67G/SG(1), 32N(2), VTFF + Voltage, Power and Energy Metering, 60CTS
										P							Extended Protection: 27P(2), 27X(1), 27P_1 (1), 59P(2), 59N(1), 59X(1), 59_2(1), 81O(2), 81U(2), 67P(1), 67N(1), 67G/SG(1), VTFF(1), 25(1), 60CTS
										W							Advanced Protection: Extended + 32(2)
Communications ^e											S	N					Standard: Front USB, Rear RS485; Modbus RTU, DNP3.0, IEC60870-5-103
											1	E					Standard + Ethernet (Copper & Fiber - MTRJ), Modbus TCP/IP, DNP3.0, IEC 60870-5-104
											2	E					Standard + Ethernet (Copper & Fiber - MTRJ), Modbus TCP/IP, DNP3.0, IEC 60870-5-104, IEC 61850 GOOSE
											3	E					Standard + Ethernet (Copper & Fiber - MTRJ), Modbus TCP/IP, DNP3.0, IEC 60870-5-104, IEC 61850
											4	E					Standard + Ethernet (Copper & Fiber - MTRJ), Modbus TCP/IP, DNP3.0, IEC 60870-5-104, IEC 61850, OPC-UA
											5	E					Standard + Ethernet (Dual Fiber - MTRJ), Modbus TCP/IP, DNP3.0, IEC 60870-5-104, OPC-UA, PRP, HSR, 1588
Case Design													D				Protection Relay with drawout design
													N				Protection Relay with non-drawout design
Harsh Environment														N			None
														H			Harsh Environment Conformal Coating

Ordering Notes:

^a. The Language option "L" is only available with the drawout Case Design "D".

^b. Phase current options "PX/P0" and Ground current options "GX/G0" are only available with the non-drawout Case Design "N".

^c. Ground currents "G1/G5" and "S1/S5" must match the corresponding "P1/P5" Phase currents (i.e. 5A and 1A must not be mixed).

Ground current .GX. must match the .PX. Phase current and is only available with the non-drawout Case Design .N., Current protection .N. and Other options .V..

Ground current "G0/S0" must match the "P0" Phase current, and is only available with the non-drawout Case Design "N".

^d. Current protection option "S" has been discontinued.

^e. Communications option .4E. allows the selection of either IEC 61850 or OPC-UA; both cannot be used at the same time.

Communications option .5E. is only available with the drawout Case Design .D.

Related Products / Accessories

- MultiSync 100 - GPS Clock MultiSync100-P
- 350 Retrofit Kit For 735 1819-0103
- 350 Retrofit Kit For IAC Relay 1819-0102
- 350 Retrofit Kit For MDP Relay 1819-0101
- 350 Retrofit Kit For S1/S2 Cut-Out 1819-0100
- SR3 Depth reducing collar - 1.375" 18L0-0076
- SR3 Depth reducing collar - 3.00" 18L0-0075
- SR3 IP20 Kit 18L0-0080

GE Grid Solutions

650 Markland St.
Markham, ON
Canada L6C 0M1

Toll Free (NA Only): 1-800-547-8629

Tel: 905-927-7070

Fax: 905-927-5098

GEGridSolutions.com

IEC is a registered trademark of Commission Electrotechnique Internationale. IEEE is a registered trademark of the Institute of Electrical Electronics Engineers, Inc. Modbus is a registered trademark of Schneider Automation. NERC is a registered trademark of North American Electric Reliability Council. ANSI is a registered trademark of American National Standards.

GE, the GE monogram, Multilin and EnerVista are trademarks of General Electric Company.

GE reserves the right to make changes to specifications of products described at any time without notice and without obligation to notify any person of such changes.

Copyright 2016, General Electric Company. All Rights Reserved.

GEA-12777Q(E)
English
160825



imagination at work