

**Company: Joyoung International Trading Co.,Limited**  
**Atten: Smiling**  
**Mobile/WhatsApp/Wechat:+86 18050035902**  
**Email: info@htechplc.com**  
**Website: <https://www.joyoungintl.com/>**

### IC660BBD120 Block High Speed Counter

Provides the wiring diagrams and installation guidelines for this GE Series 90-30 module.

# High-speed Counter Block

June 2002

GFK-0367E

## Description

The High-speed Counter block (IC66\*BBD120) provides direct processing of rapid pulse signals up to 200KHz for industrial control applications such as:

- Turbine flowmeter
- Meter proving
- Velocity measurement
- Material handling
- Motion control

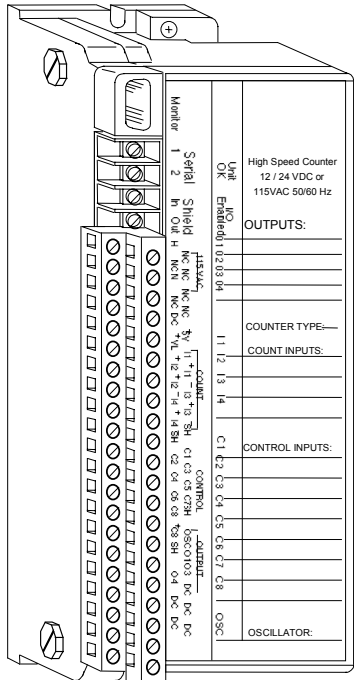

## Features

Block features include:

- 12 inputs and 4 outputs, plus a +5 volt DC output and an oscillator output
- Counts per timebase register for each counter
- Software configuration
- Failed Switch diagnostic
- Use of 115 VAC and/or 10 VDC to 30 VDC block power
- External battery backup operation
- Built-in protection against power surges on outputs

The High-speed Counter can easily be configured to count either up or down, to count both up and down, or to count the difference between two changing values.

The block provides 1, 2, or 4 counters of differing complexity:

- Four identical, independent simple counters
- Two identical independent counters of moderate complexity
- One complex counter

Direct processing means that the block is able to sense inputs, count, and respond with outputs, without needing to communicate with a CPU.

## Specifications

### Catalog Numbers

High-speed Counter Block	IC66*BBD120
Terminal Assembly	IC66*TBD120
Electronics Assembly	IC66*EBD120

### Block Specifications

Size (height x width x depth)	8.83" (22.43 cm) x 3.58" (9.1 cm) x 4.7" (11.94 cm)	
Weight	4 lbs. (1.8 kg)	
LEDs (I/O Block)	Unit OK, I/O Enabled	
LEDs (circuit)	Output status: logic side (four)	
Operating voltage	93V to 132VAC	10V to 30VDC
Frequency/ripple	47Hz to 63Hz	10% maximum
Required AC power	60mA typical	250mA typical
Required DC power	200mA typical/300mA max. @ 12 volts	
DC power supply dropout time	10ms at 12 volts/75ms at 24 volts	
AC power supply dropout time	1 cycle	

### Input Specifications

Input voltage relative to DC-	VL+ (load voltage): 5V DC to 30V DC
Input ON:	
TTL single-ended	Vin > or = 2.0V (sourcing 1mA min)
non-TTL single-ended	Vin > or = 7.2V (sourcing 1.75mA min)
TTL-differential	Vin+ > or = 0.85V (sourcing 1mA min)
non-TTL-differential	Vin+ > or = 4.1V (sourcing 1mA min)
Input OFF:	
TTL single-ended	Vin < 0.8V
non-TTL single-ended	Vin < 6.0V
TTL-differential	Vin+ < 0.50V
non-TTL-differential	Vin+ < 3.9V
Input impedance (typical)	4.0 Kohms
Input response time	0.5ms (plus selectable filter delays)
Selectable input filter times	High (2.5µs) or low (12.5ms) frequency
Input pulse width	High-frequency filter selected: 2.5µs minimum Low-frequency filter selected: 12.5ms minimum
Count rate	High-frequency filter selected: 200 KHz maximum Low-frequency filter selected: 40 Hz maximum

### Output Specifications

+5V	4.75V DC to 5.25V DC at 200mA
Steady state output current	0.5 Amps maximum per output (01 - 04)
OSC (oscillator output)	3.8V at 4.0mA
Inrush current	3 Amps per input for up to 10ms, maximum
Circuit overcurrent threshold	4 Amps, maximum c
Steady state output current	Block: 2 Amps maximum
Output OFF leakage current	10µA, maximum
Switching frequency	once/second (high inrush current), maximum
Input-to-Output delay	200µs (min)/1ms (max) + input filter selected
Output voltage drop	2.0 volts maximum at 4 Amps inrush 0.25 volt maximum at 0.5 Amp

### Environmental Specifications

Operating temperature	0° C to 60° C (32° F to 140° F)
Storage temperature	-40° C to 100° C (-40° F to 212° F)
Humidity	5% to 95% (non-condensing)
Vibration	5-10Hz x 0.2" (5.08mm) displacement, 10-200 Hz at 1G

Refer to GFK-0867 for product standards and general specifications.

# High-speed Counter Block

June 2002

GFK-0367E

## Using this Datasheet

This datasheet summarizes information about block installation, configuration, and diagnostics.

Your primary reference should be the *Discrete and Analog Blocks User's Manual*. It includes detailed instructions for block installation and configuration. For additional information about systems and communications, including bus specifications, refer to the *I/O System and Communications Manual*.

## Compatibility

This block requires Hand-held Monitor version 3.5 (IC66\*HHM501D) or later. HHM version 4.0 or later is required to use all the features described in this datasheet.

For the IC600 series PLC, bus controller version IC66\*CBB902G or IC66\*CBB903G or later is required for blocks assigned to I/O references, to assure data coherency. For blocks assigned to register memory, earlier versions of bus controllers IC66\*CBB902 and IC66\*CBB903 can be used. Bus controllers IC66\*CBB900 and IC66\*CBB901 cannot be used with a High-speed Counter.

## Block Operation

The High-speed counter block accepts 12 input signals, and provides 4 output signals for counter operations.

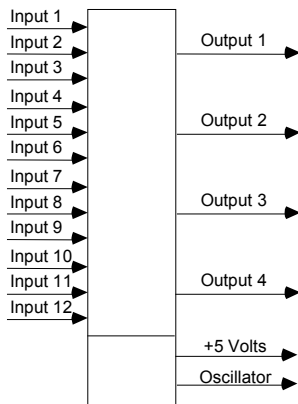

Inputs can be used for count signals, direction, disable, edge-sensitive strobe, and other inputs.

Outputs can be used to drive indicating lights, solenoids, relays, and other devices. Each output has a response delay of 1ms maximum; repeatability is 0.5ms or less. Each output circuit provides built-in protection against power surges caused by wiring errors.

The block also provides a +5 volt DC output and a CMOS/TTL-compatible oscillator output.

The block's Counts Per Timebase register indicates the number of counts in a programmable time interval. For each counter, this is a 16-bit signed number. The sign indicates net up counts (+) or down counts (-) in the time period.

The block may be powered by 115 VAC or 10 to 30 VDC. Auxiliary DC power can be used when the main power to the block is supplied by 115 VAC. Both 115 VAC and DC power may be supplied simultaneously and if the 115 VAC source fails, the block will continue to operate on the DC backup power. Any DC source that can provide an output in the range of 10 VDC to 30 VDC can be used. The source must meet the specifications listed in the table on page 1 of this datasheet. With both AC and DC power applied, block power will be taken from the AC input as long as the DC voltage is less than 20 volts.

The block is configured for the application to function in one of the following ways:

- as four 16-bit counters. Each of the four may independently count either up or down. This block configuration is referred to as "Type A".
- as two 24-bit counters. Each may independently operate in Up/Down, Pulse/Direction, or A Quad B mode. This configuration is referred to as "Type B".
- as one 24-bit differential counter, which can operate in Up/Down, Pulse/Direction, or A Quad B mode. This is referred to as "Type C" configuration.

The block's outputs can be programmed to turn on or off when the accumulated count reaches appropriate Preset values, as shown by the following example.

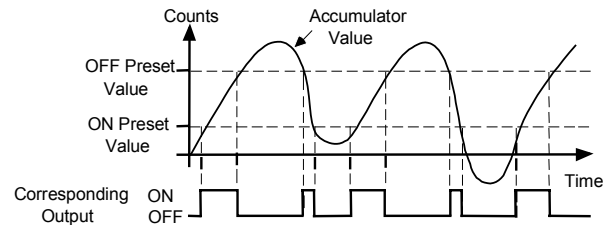

Each output has a response delay of 1ms maximum; repeatability is 0.5ms or less. The commanded state of each output is shown by an individual LED on the block. Outputs may be forced on or off using the Hand-held Monitor, or by command from the application program. This is useful during installation and checkout.

Each output has built-in electronic protection against short circuits. If an output is commanded to turn on and the current through the switch exceeds 4 Amps for a period of 1 millisecond, the block automatically shuts off the switch and generates a FAILED SWITCH diagnostic.

Short circuit protection protects the block if loads are 4 Amps or more. Each output on the block can source a maximum of 0.5 Amps. Switching of loads between 0.5 Amps and 4 Amps is shown below.

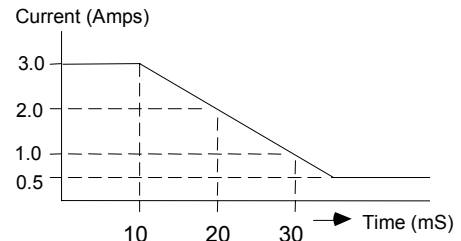

# High-speed Counter Block

June 2002

GFK-0367E

## Installation Instructions

Carefully inspect all shipping containers for damage. If any equipment is damaged, notify the delivery service immediately. Save the damaged shipping container for inspection by the delivery service. After unpacking the equipment, record all serial numbers. Save the shipping containers and packing material in case it is necessary to transport or ship any part of the system.

### Block Mounting

Genius I/O blocks are considered "open equipment" and therefore must be installed within a protective enclosure. They should be located in an area that is clean and free of airborne contaminants. There should be adequate cooling airflow.

The block can be mounted right side up, or upside down. Leave at least 2 inches of space between blocks. Mount the block by drilling two screw or bolt holes for 8-32 hardware. Position the block so that the notches in the upper and lower flanges line up with the mounting holes. Mount the block using 8-32 screws. Use star washers to provide ground integrity.

### Grounding

The block's mounting screws must not be used as the only means of grounding the block. Connect the green ground screw on the block to a reliable ground system using a short wire lead, minimum size AWG #12 (avg 3.3mm<sup>2</sup> in cross-section).

#### Warning

**If mounting screws do not make good ground connection and the ground screw is not connected to a reliable ground, the block is not grounded. Electrical shock hazard exists. Death or personal injury may result.**

## Removing an Electronics Assembly

The block's Electronics Assembly can be replaced with a compatible model without removing field wiring or reconfiguring the block.

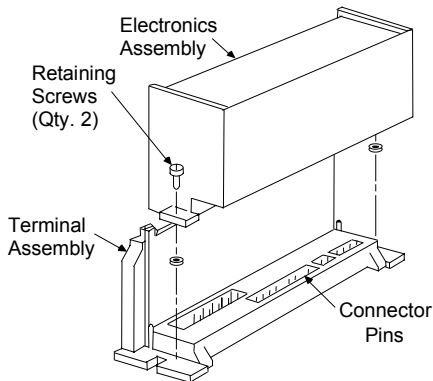

1. Unscrew the retaining screws at the top and bottom of the block.
2. Using a Block Puller (IC660BLM507), engage the tabs in the first vent slots. Move the tool to the center of the block and squeeze the handle.
3. Pull the Electronics Assembly upward.

#### Warning

**If power is applied to the field terminals, power is also exposed on the connector pins at the base of the Terminal Assembly, and electrical shock hazard exists. Do not touch the connector pins! Death or injury may result.**

## Inserting an Electronics Assembly

1. Align the Electronics Assembly in the guides and push down firmly.

#### Caution

**Do not exert excessive force; it may damage the block.**

2. If unusual resistance is met, remove the Electronics Assembly. If power is applied to the block, DO NOT TOUCH THE CONNECTOR PINS! Inspect the Terminal Assembly, connector receptacle, and connector edge board (on the Electronics Assembly). Be sure the keying matches. Remove any obstacles and reinsert the Electronics Assembly. Pay close attention to the alignment of the guide pins.
3. Secure the Electronics Assembly with the screws on the top and bottom of the Terminal Assembly.

Note: If the Electronics Assembly has been removed from a block for some length of time, contaminants may have built up on the exposed connector pins. After the block is reassembled, these contaminants could affect the accuracy of measurements. When reassembling the block, push the Electronics Assembly in and out a few times to assure a fresh mating surface.

## LEDs

The block's Unit OK and I/O Enabled LEDs show its operating status:

Unit OK	I/O Enabled	Meaning
ON	ON	Block functioning, CPU communicating
ON	OFF	Block functioning No CPU communications for 3 bus scans
ON	Blinking	Block functioning, Circuit forced
Blinking	ON	Circuit fault, CPU communicating
Blinking	OFF	Circuit fault No CPU communications for 3 bus scans
Alternate Blinking		Circuit fault, Circuit forced
Synchronous Blinking		No CPU communications - block number conflict
OFF	don't care	Electronics/Terminal Assembly mismatch

Individual circuit LEDs show the commanded state of each output.

# High-speed Counter Block

June 2002

GFK-0367E

## Block Wiring

Do not overtorque the terminal screws. Recommended torque for all terminals is 6 in/lb (.678 N/M).

### Serial Bus Wiring

Terminals 1 to 4 are for the serial bus. These terminals accept one AWG #12 wire (avg 3.3mm<sup>2</sup> cross-section) or two AWG #14 wires (each avg 2.1mm<sup>2</sup> in cross-section). The minimum recommended wire size is AWG #22 (avg .36mm<sup>2</sup> in cross-section).

Terminals 1 - 4 can also accommodate spade or ring terminals up to 0.27 inch (6.85mm) wide with a minimum opening for a #6 screw, and up to 0.20 inch (5.1mm) depth from the screw center to the back barrier. Be sure unshielded wire ends are not longer than 2 inches (5 cm).

Using one of the cable types recommended in the *System and Communications User's Manual*, connect the serial bus to terminals 1 - 4.

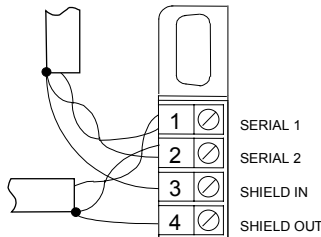

If the block is at either end of the bus, connect a terminating resistor of the appropriate type (see the *System and Communications User's Manual* for details) across its Serial 1 and Serial 2 terminals.

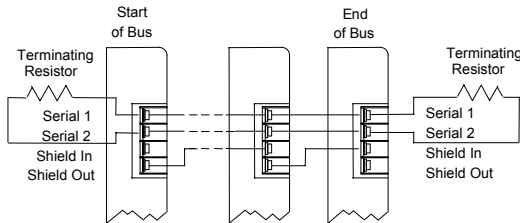

### Installing a Bus Switching Module

If a Bus Switching Module will be connected *directly* to the block, install it at the block's serial bus terminals, as shown at right. Connect the bus cables to the BSM. Connect either of the BSM pigtail wires to terminals 7. Connect the other to terminal 8.

### Field Wiring

Terminals 5 to 46 are for field devices. Each terminal accepts one AWG #14 wire (avg 2.1mm<sup>2</sup> in cross section), two AWG #14 (2.1mm<sup>2</sup> cross section) solid wires, or two AWG #16 (each avg 1.3mm<sup>2</sup> in cross section) stranded wires. Minimum recommended wire size is AWG #22 (avg .36mm<sup>2</sup> in cross section).

The table below shows terminal assignments for field wiring to each block type (A, B, and C). For all block types, connect differential inputs to the terminals as shown. Connect the + input to the + terminal, and the - input to the - terminal. For single-ended signals (abbreviated "se" in the table) make a connection to the + diff terminal only. Leave the - terminal unconnected.

Terminal 36, labelled OSC, is a CMOS/TTL compatible totempole output. Do not use an external pullup resistor for this terminal.

Terminals O1 through O4 are for outputs that will be driven by a DC power supply wired to VL+ (terminal 15). This voltage may vary

from 5 volts to 30 volts DC, depending on the output level needed. The maximum steady-state current supplied by any output is 0.5 amp.

For both AC and DC block power, the 5V+ terminal (terminal 14) can be used to drive any load, including output loads, that falls within its capacity of 4.75 to 5.25 volts at 200 mA.

### Caution

**Do not apply loads greater than 200mA to the +5V output (terminal 14). Doing so may damage the block.**

Terminal	Type A	Type B	Type C
5	Hot	hot side of AC line	
6	NC	no connection	
7	NC	no connection	
8	NC	no connection	
9	N	neutral side of AC line	
10	NC	no connection	
11	NC	no connection	
12	NC	no connection	
13	DC+	block power (+ side 10-30V source)	
14	+5V	+5V output at 200mA	
15	VL+	load power (+ side 5-30V source)	
16	I1+	pulse input for ctr 1 (se/diff)	pul1 / up1 / A1 + for ctr 1 (se/diff) / pul1 / up1 / A1 + for + loop (se/diff)
17	I2+	pulse input for ctr 2 (se/diff)	dir 1 / dn1 / B1 + for ctr 1 (se/diff) / dir 1 / dn1 / B1 + for + loop (se/diff)
18	I1-	pulse input for ctr 1 (diff only)	pul1 / up1 / A1 - for ctr 1 (diff only) / pul1 / up1 / A1 - for - loop (diff only)
19	I2-	pulse input for ctr 2 (diff only)	dir1 / dn1 / B1 - for ctr 1 (diff only) / dir1 / dn1 / B1 - for + loop (diff only)
20	I3+	pulse input for ctr 3 (se/diff)	pul 2 / up2 / A2 + for ctr 2 (se/diff) / pul 1 / up1 / A1 + for - loop (se/diff)
21	I4+	pulse input for ctr 4 (se/diff)	dir 2 / dn2 / B2 + for ctr 2 (se/diff) / dir 1 / dn1 / B1 + for - loop (se/diff)
22	I3-	pulse input for ctr 3 (diff only)	pul2 / up2 / A2 - for ctr 2 (diff only) / pul1 / up1 / A1 - for - loop (diff only)
23	I4-	pulse input for ctr 4 (diff only)	dir2 / dn2 / B2 - for ctr 2 (diff only) / dir1 / dn1 / B1 - for - loop (diff only)
24	SHD	shield	
25	SHD	shield	
26	C1	preload 1	
27	C2	preload 2	
28	C3	preload 3	disable 1
29	C4	preload 4	disable 2
30	C5	strobe 1	strobe 1 for counter 1
31	C6	strobe 2	strobe 2 for counter 1
32	C7	strobe 3	strobe 1 for counter 2
33	C8+	strobe 4 (se/diff)	strobe 2 for counter 2 (se/diff) / marker input from encoder (se/diff)
34	SHD	shield	
35	C8-	strobe 4 (diff only)	strobe 2 for counter 2 (diff only) / marker input from encoder (diff)
36	OSC	oscillator output	
37	SHD	shield	
38	O1	output 1	output 1 for counter 1
39	O2	output 2	output 2 for counter 1
40	O3	output 3	output 1 for counter 2
41	O4	output 4	output 2 for counter 2
42	DC-	return for all DC sources	
43	DC-	return for all DC sources	
44	DC-	return for all DC sources	
45	DC-	return for all DC sources	
46	DC-	return for all DC sources	

# High-speed Counter Block

June 2002

GFK-0367E

## Wiring for Block Power

The block may be powered by 115VAC (at 60mA typical) or 10VDC to 30VDC (at 250mA typical). If the block is powered by an AC source, DC power can also be applied as a backup.

### AC Block Power

For an AC power source, connect the HOT lead to the terminal. Connect neutral to the N terminal. If Class 1 Division 2 conditions must be met for Factory Mutual, install an external 250-volt 1/8 Amp slow-blow fuse in series with the H terminal.

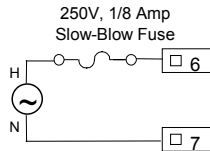

This illustration shows connections for AC block power with an external DC source for the outputs (see *Output Power Connections*).

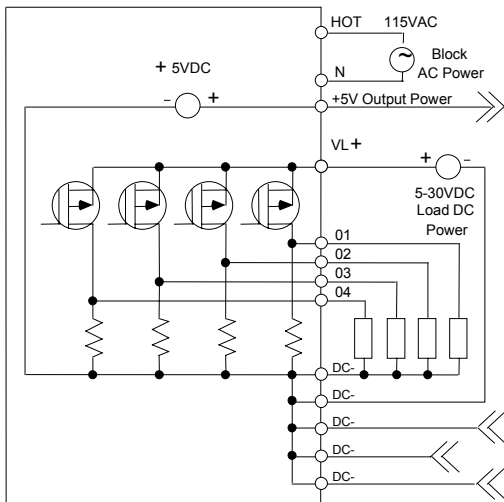

### AC Block Power with DC Backup

When using AC power, DC power input may also be connected as a backup.

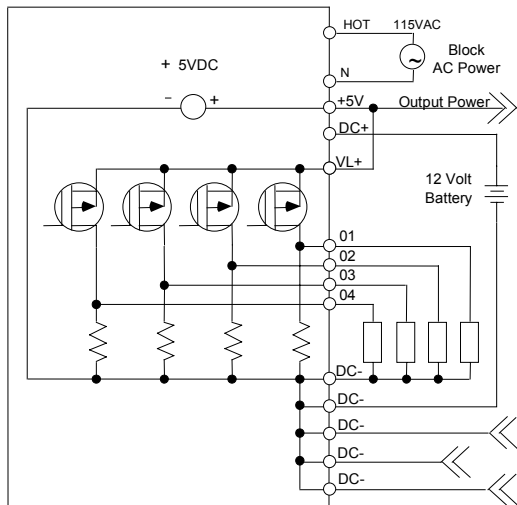

Any 10 to 30 VDC source can be used. With both AC and DC power applied, block power will be taken from the AC input as long as the DC voltage is less than 20 volts. Above 20 volts, block power is drawn from the DC input, even if AC power is still applied. Connect the AC source to the Hot and Neutral terminals. Connect the DC backup to DC+ and DC-. The following illustration shows connections for AC block power with DC backup, and output power from the block's 5-volt output (see *Output Power Connections*).

### DC Block Power

If the block will be powered by a 10VDC to 30VDC source, connect the + side of the source to the DC+ terminal (terminal 13). Connect the - side to any DC- terminal (terminals 42 through 46). The following illustration shows connections for DC block power with a separate external DC source for the outputs (see *Output Power Connections*).

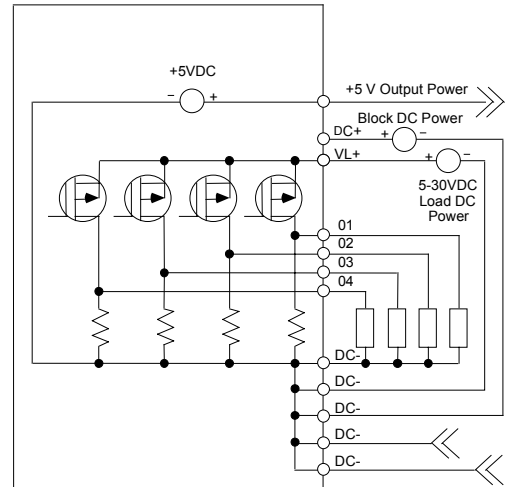

### Output Power Connections

The block's four outputs (O1 through O4) require a 5VDC to 30VDC source. If logic-level signals are needed for the outputs and their total load will not be more than 200mA, the block's +5V output can be used as the power source. Output power can also come from the same DC source used for block power, or a separate DC power source.

#### Connecting VL+

If no block outputs (O1 through O4) will be used, jumper the block's +5V output to VL+. If VL+ is not connected, the block will generate false Failed Switch messages.

#### Output Power from the +5V Terminal

To use the block's +5VDC output as the output power source, jumper the +5 volt output terminal to VL+. See the illustration for *AC Power with DC Backup*.

#### Output Power from the DC Block Power Source

If outputs will be powered by the same DC source used for block power, jumper VL+ to DC+.

#### Output Power from a Separate DC Source

If output power will come from a separate external DC source (not the same power supply used for block power), install the external source across the VL+ and DC- terminals. See the illustrations.

# High-speed Counter Block

June 2002

GFK-0367E

## Configuration

First, the block must be configured with a Hand-held Monitor to:

- Enter its Device Number (serial bus address).
- Enter its Reference Number (required only for IC600 and IC550 series PLCs only).
- Enter its counter type (A, B, or C).

**Note:** If a block is configured offline, it must be properly grounded and have a 75 Ohm resistor installed across its Serial 1 and Serial 2 terminals. See the *High-speed Counter User's Manual* for instructions. The rest of the features can be configured either using a Hand-held Monitor, or by sending a Write Configuration datagram to the block from the host.

**Note:** If the counter is operating at a count rate of 150KHz or higher, run-time configuration changes should be made using a Hand-held Monitor.

Feature	Factory Setting	Selections
Device Number	null	0 to 31 (a number must be selected)
Reference Address	none	Depends on host CPU type
Baud Rate	153.6 std	153.6 std, 153.6 ext, 76.8, 38.4 Kbd
Pulse Test	enabled	enabled/disabled
Powerup Outputs En.	disabled	enabled/disabled
Oscillator Frequency (KHz)	170/N, (10 KHz)	1360/N, 170/N, 10.625/N
Divider (N)	17	1-255
Control Input T'hold	non-TTL	TTL/non-TTL
Counter Input T'hold	non-TTL	TTL/non-TTL
Report Faults	yes	yes/no
Strobe edge	positive	positive/negative
Strobe mode	first	not latched (first), latched (last)
Strobe effect*	Strobe only	Strobe only, Strobe then Preload
Strobe Linkage****	independent	independent, coupled to Accumulator 2
Disable Input filter**	high	high/low frequency
Preload Input filter	high	high/low frequency
Count input filter	high	high/low frequency
Count Up or Down*	up	Up/down
Count input signals**	PUL/DIR	UP/DN,PUL/DIR, A QUAD B
Count mode	continuous	Continuous/single
Counter timebase	1000ms	1 - 65535ms
Count limits	upper = max + lower = 0	A:-32768 to +32767 B/C:-8388608 to +8388607
Output Presets	ON = max + OFF = 0	enter values
Home position***	0	enter value
Preload value	0	A:-32768 to +32767 B/C:-8388608 to +8388607
CPU Redundancy	none	none/standby
Configuration Protection	disabled	enabled, disabled

\* for type A configuration only  
 \*\* for type B or type C configuration  
 \*\*\* for type C configuration only  
 \*\*\*\* for type B only